

Inhoudsopgave

Drijfwerk Huis '04	7
Index	43
Motorsteun & Kappen	3
PTO & Tandwielen	9
Schakelpoken '04	33
Stickers '03 13	41
Stuur & Kabels	27
Stuurboom	25
Wielas Koppeling '04	21
Wielen	35

Code	Description	Notes
001_4_12698	BODYGUARD	
003_1_12834	GEARBOX (500-520/30-530S/S2)	
03B_0_13977	GEARBOX (530S2)	
004_2_12967	GEARS (500-520/30-530S/S2)	
05C_0_14191	WHEEL AXLE (530S2)	
05C_1_14218	WHEEL AXLE (530S2)	
05D_0_14243	WHEEL AXLE (530S2)	
05D_1_14293	WHEEL AXLE (530S2)	
007_3_13177	STEERING COLUMN (500/10/20/30-530S/S2)	
08C_0_14518	HANDLEBAR (530S2)	
009_3_13564	CONTROLS(500/10/20/30-530S/S2)	
009_4_13594	CONTROLS(500/10/20-530-530S2)	
011_3_13744	WHEELS	
012_2_13824	STICKERS	
013_1_13860	STICKERS	

500

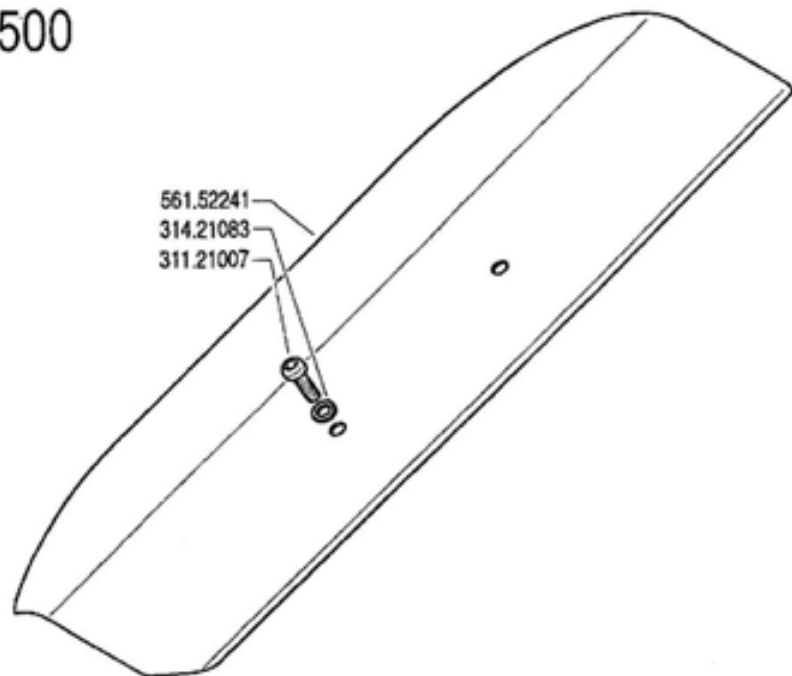

510 - 520 - 530 - 530S ★ - 530S2 ★

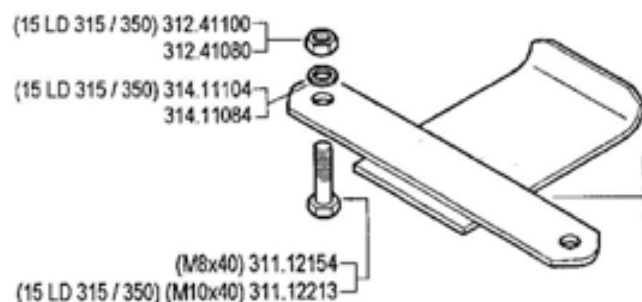
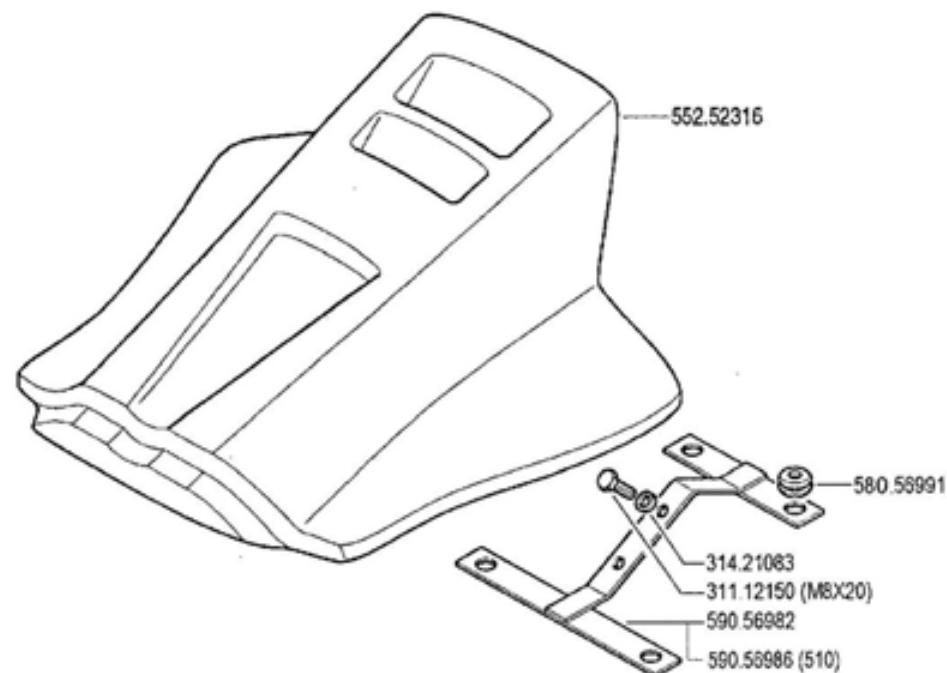

- 561.56118 ★ (ACT 280 / 340)
- 590.56051 (15 LD 315 / 350)
- 590.56089 (HONDA Gx120 ★ - Gx160 - Gx200)
- 590.56111 (Yanmar L100 AE)

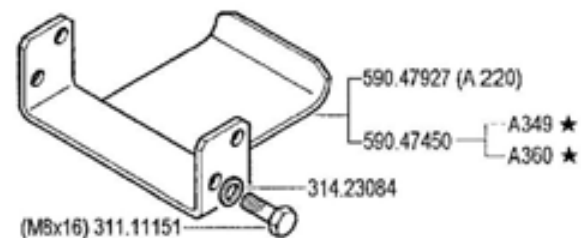

FERRARI

500 serie **95**

BODY
CARROCERIA

CARROZZERIA

CARROSSERIE
KAROSSERIE

DALLA MACCHINA
DE LA MAQUINA
DE LA MACHINE
FROM THE MACHINE
AB DER MASCHINE

AGGIORNAMENTO
REVISION
MISE A JOUR
APLAZAMIENTO
ANPASSUNG

01

Rev.
4

10/2001

★N.

ZUM

Pos.	Code	Q.ty	Description	Notes
31111151	31111151	0	SCREW TE M8X16 UNI 5739 8G	
31112150	31112150	0	SCREW TE M8X20 UNI 5739 8G	
31112154	31112154	0	SCREW TE M8X40 UNI 5739 8G	
31112213	31112213	0	SCREW TE M10X40 UNI 5739	
31121007	31121007	0	SCREW BCEI M8X20 ISO7380	
31241080	31241080	0	SELFLOCK NUT M8	
31241100	31241100	0	SELFLOCK NUT M10 6S	
31411084	31411084	0	WASHER 8,4x17	
31411104	31411104	0	WASHER 10,5x18	
31421083	31421083	0	WASHER	
31423084	31423084	0	SPRING WASHER 8,4	
55252316	55252316	0	BODYWORK	
56152241	56152241	0	CARROZZERIA MF LAT./97 *V*	
56156119	56156119	0	SHIELD	
58056991	58056991	0	CABLE GLAND	
58057385	58057385	0	LINE	
59047450	59047450	0	SHIELD	
59047927	59047927	0	SHIELD	
59056051	59056051	0	SHIELD	
59056089	59056089	0	SHIELD	
59056111	59056111	0	SHIELD	
59056982	59056982	0	HOLDER	
59056986	59056986	0	HOLDER	

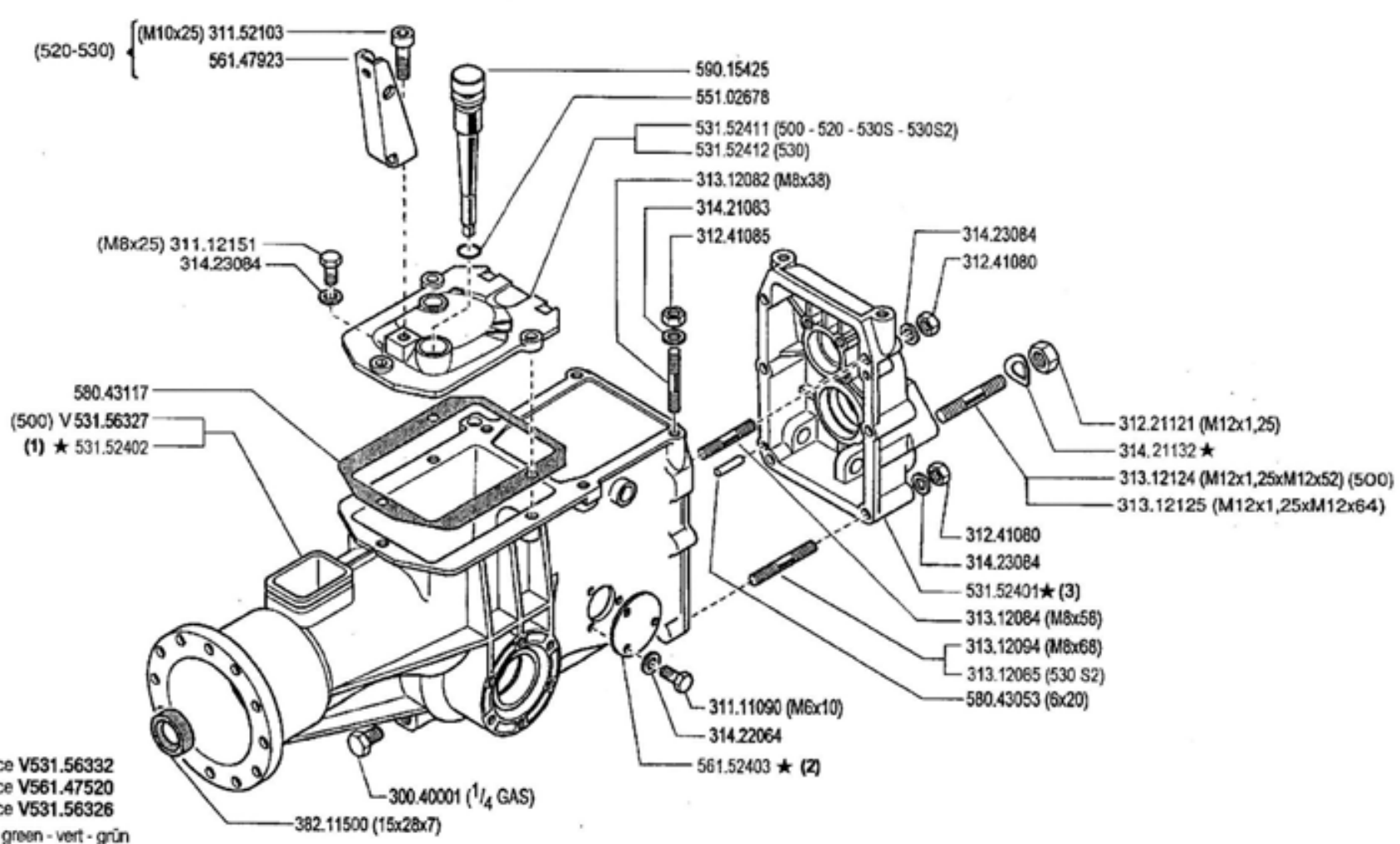

FERRARI

500 serie 95

SCATOLA CAMBIO (500 - 520 - 530 - 530S - 530S2)

GEARBOX
CAJA DE CAMBIO

BOITE DE VITESSES
WECHSELGETRIEBE

DALLA MACCHINA
DE LA MAQUINA
DE LA MACHINE
FROM THE MACHINE
AB DER MASCHINE

AGGIORNAMENTO
REVISION
MISE A JOUR
APLAZAMIENTO
ANPASSUNG

03 Rev. **1**

12/2002

★ N.

20002

Pos.	Code	Q.ty	Description	Notes
30040001	30040001	0	PLUG	
31111090	31111090	0	SCREW TE M5X10 UNI 5739 8G	
31112151	31112151	0	SCREW TE M8X25 UNI 5739 8G	
31152103	31152103	0	SCREW TCEI M10X25 UNI 5931	
31221121	31221121	0	NUT M12X1,25	
31241080	31241080	0	SELFLOCK NUT M8	
31241085	31241085	0	SELFLOCK NUT M8 6S	
31312082	31312082	0	STUD BOLT M8X38X14X20	
31312084	31312084	0	STUD BOLT M8X58X16X16	
31312085	31312085	0	STUD BOLT M8X80X28X16	
31312094	31312094	0	STUD BOLT M8X68X14X36	
31312124	31312124	0	STUD BOLT	
31312125	31312125	0	STUD BOLT	
31421083	31421083	0	WASHER	
31421132	31421132	0	WASHER 13X24X2,8	
31422064	31422064	0	SPRING WASHER 6,4	
31423084	31423084	0	SPRING WASHER 8,4	
38211500	38211500	0	OIL SEAL 15X28X7	
53152401	53152401	0	REAR COVER	
53152402	53152402	0	BODY	
53152411	53152411	0	GEARBOX HOUSING COVER	
53152412	53152412	0	COPERCHIO SCAT.CAMBIO DIFF.*V*	
53156327	53156327	0	BODY	
55102678	55102678	0	RUBBER RING	
56147923	56147923	0	BRACKET	
56152403	56152403	0	COVER	
58043053	58043053	0	CYLINDRICAL PLUG	
58043117	58043117	0	COVER GASKET	
59015425	59015425	0	PLUG	

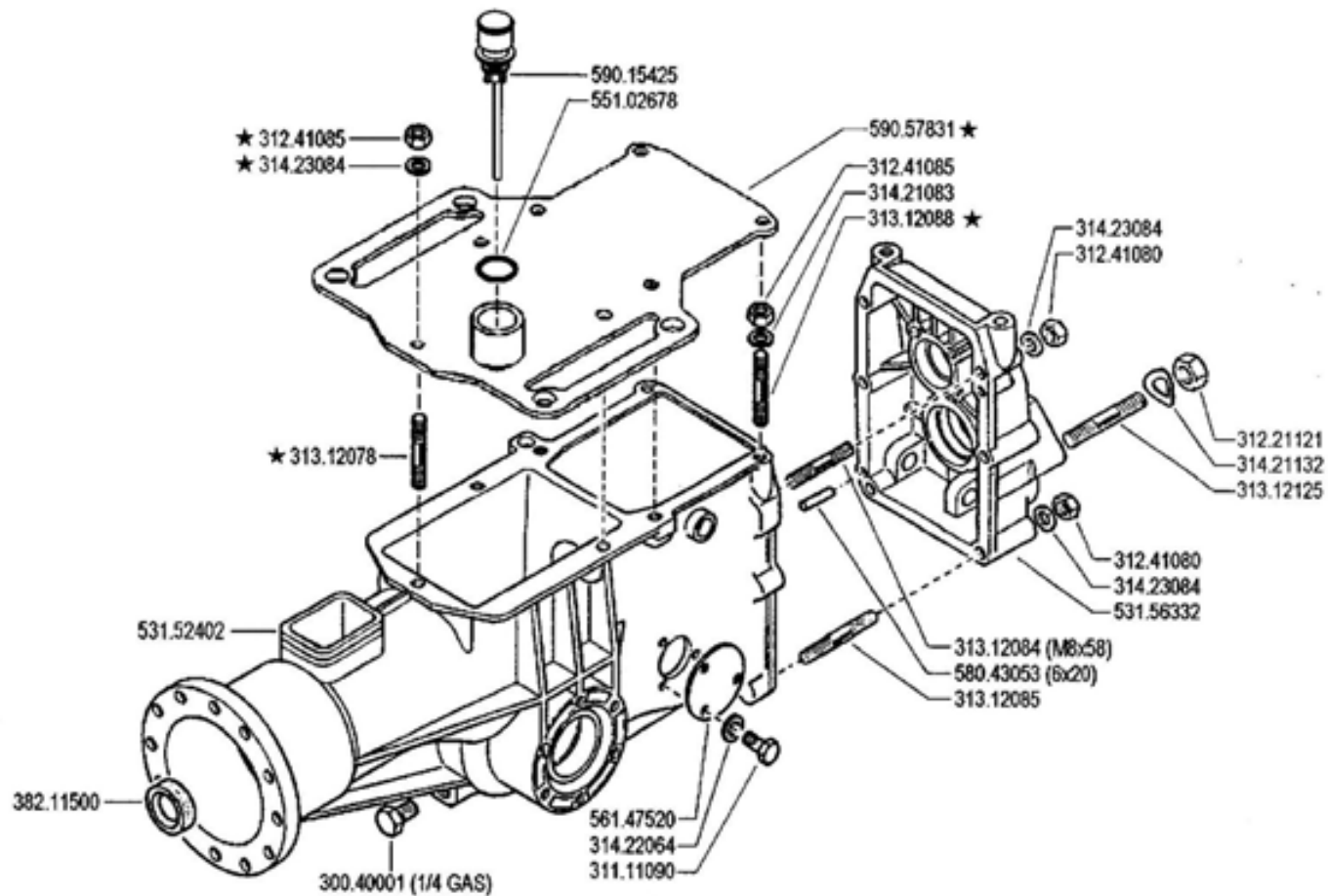

FERRARI

500 serie **95**

SCATOLA CAMBIO (530S2)

GEARBOX
CAJA DE CAMBIO

BOITE DE VITESSES
WECHSELGETRIEBE

★ DALLA MACCHINA
DE LA MAQUINA
DE LA MACHINE
FROM THE MACHINE
AB DER MASCHINE

ALLA MACCHINA
A LA MAQUINA
A LA MACHINE
TO THE MACHINE
BIS MASCHINE

03 B 0

Rev.

N. 721207
721255

721222

1/2004

5296

Pos.	Code	Q.ty	Description	Notes
30040001	30040001	0	PLUG	
31111090	31111090	0	SCREW TE M5X10 UNI 5739 8G	
31221121	31221121	0	NUT M12X1,25	
31241080	31241080	0	SELFLOCK NUT M8	
31241085	31241085	0	SELFLOCK NUT M8 6S	
31312078	31312078	0	STUD BOLT M8X32X14X14	
31312084	31312084	0	STUD BOLT M8X58X16X16	
31312085	31312085	0	STUD BOLT M8X80X28X16	
31312088	31312088	0	STUD BOLT M8X40X14X14	
31312125	31312125	0	STUD BOLT	
31421083	31421083	0	WASHER	
31421132	31421132	0	WASHER 13X24X2,8	
31422064	31422064	0	SPRING WASHER 6,4	
31423084	31423084	0	SPRING WASHER 8,4	
38211500	38211500	0	OIL SEAL 15X28X7	
53152402	53152402	0	BODY	
53156332	53156332	0	REAR COVER	
55102678	55102678	0	RUBBER RING	
56147520	56147520	0	COVER	
58043053	58043053	0	CYLINDRICAL PLUG	
59015425	59015425	0	PLUG	
59057831	59057831	0	PLATE	

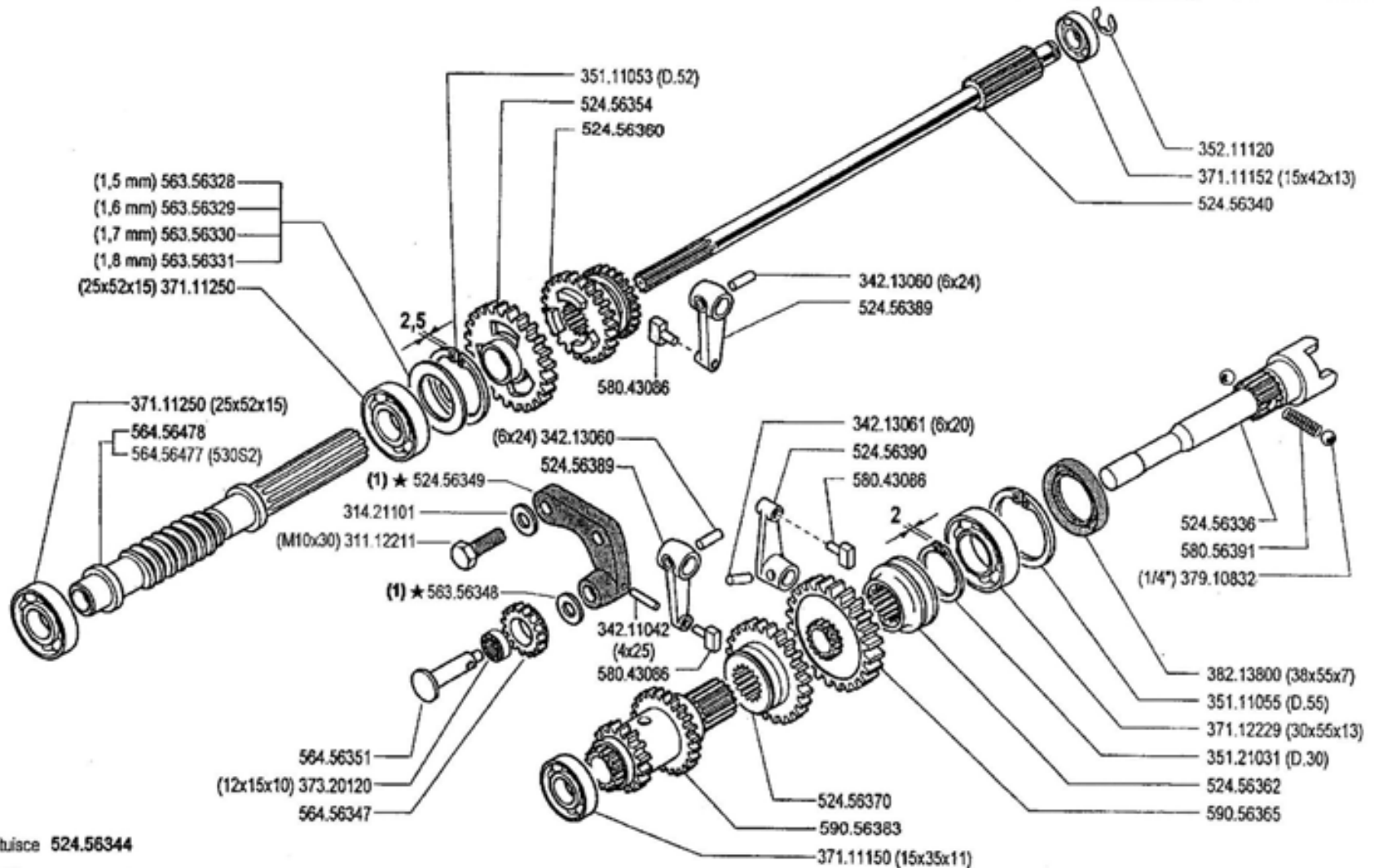

(1) sostituisce 524.56344

FERRARI	500 serie 95	INGRANAGGI CAMBIO (500 - 520 - 530 - 530S - 530S2) ★		DALLA MACCHINA DE LA MAQUINA DE LA MACHINE FROM THE MACHINE AB DER MASCHINE ★N.	AGGIORNAMENTO	04	Rev.
		GEARS ENGRANAJES	ENGRANAGES ZAHNRÄDER		REVISION MISE A JOUR APLAZAMIENTO ANPASSUNG		2
					9/2000		

Pos.	Code	Q.ty	Description	Notes
31112211	31112211	0	SCREW TE M10X30 UNI 5739	
31421101	31421101	0	WASHER	
34211042	34211042	0	ROLL PIN	
34213060	34213060	0	ROLL PIN	
34213061	34213061	0	ROLL PIN	
35111053	35111053	0	SEEGER RING I 52 UNI 7438	
35111055	35111055	0	SEEGER RING I 55 DIN 472	
35121031	35121031	0	SEEGER RING E 30 UNI 7436	
35211120	35211120	0	SEEGER RING E 12 UNI 7434	
37111150	37111150	0	BEARING	
37111152	37111152	0	BEARING	
37111250	37111250	0	BEARING	
37112229	37112229	0	BEARING	
37320120	37320120	0	ROLLER CAGE 12X15/10	
37910832	37910832	0	BALL 1/4	
38213800	38213800	0	OIL SEAL 38X55X7	
52456336	52456336	0	PTO SHAFT	
52456340	52456340	0	SHAFT	
52456349	52456349	0	GEAR SUPPORT	
52456354	52456354	0	GEAR	
52456360	52456360	0	SLIDER	
52456362	52456362	0	COUPLING	
52456370	52456370	0	SLIDER	
52456389	52456389	0	LEVER	
52456390	52456390	0	LEVER	
56356328	56356328	0	ADJUSTING RING SP=1,5	
56356329	56356329	0	ADJUSTING RING SP=1,6	
56356330	56356330	0	ADJUSTING RING SP=1,7	
56356331	56356331	0	ADJUSTING RING SP=1,8	
56356348	56356348	0	ADJUSTING RING	
56456347	56456347	0	GEAR	
56456351	56456351	0	GEAR PIN	
56456477	56456477	0	SCREW	
56456478	56456478	0	SCREW	

SERIAL

GEARS (500-520/30-530S/S2)

CODE REV

004_2_12967

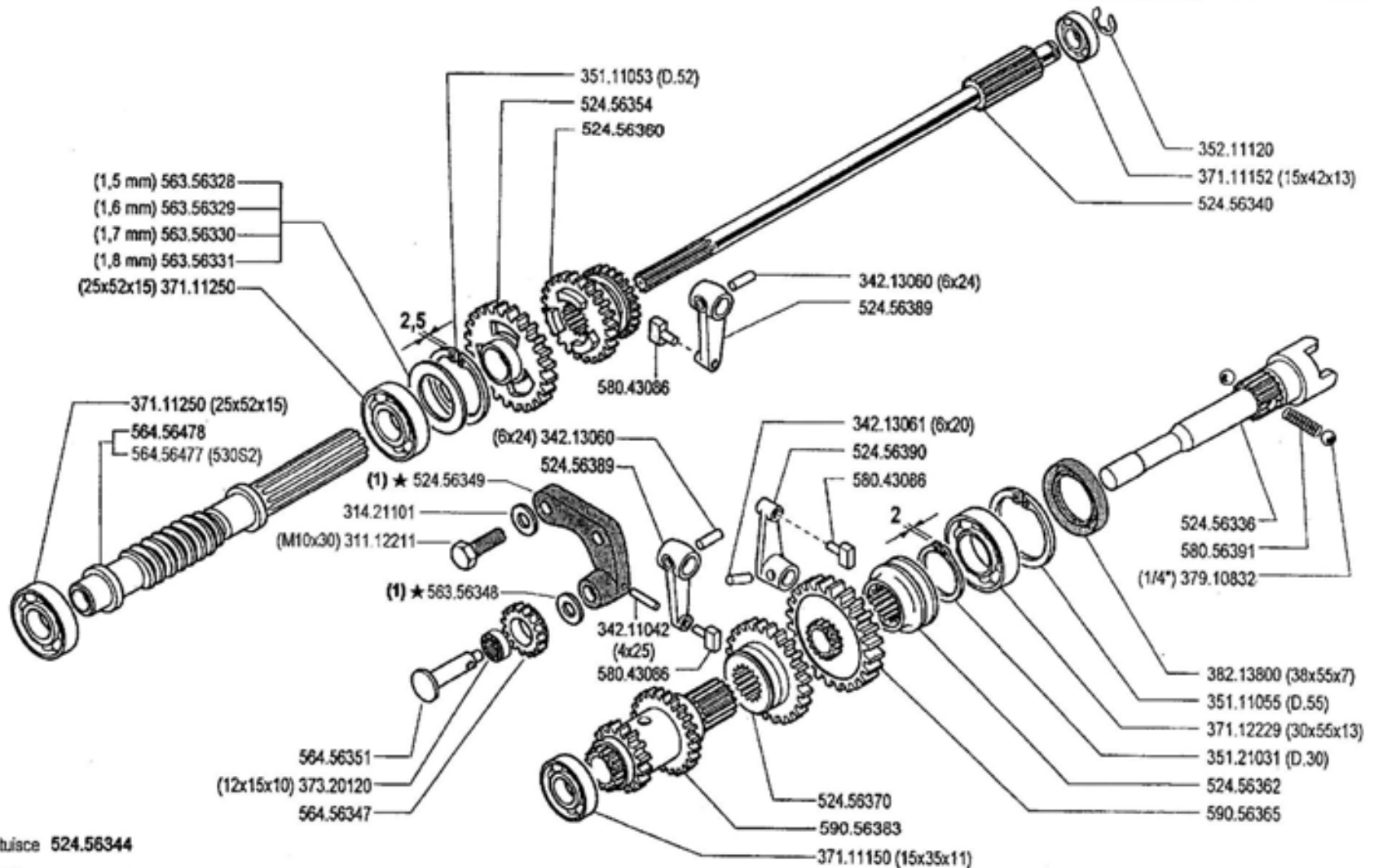

(1) sostituisce 524.56344

FERRARI 500 serie 95	INGRANAGGI CAMBIO (500 - 520 - 530 - 530S - 530S2) ★		DALLA MACCHINA DE LA MAQUINA DE LA MACHINE FROM THE MACHINE AB DER MASCHINE ★N.	AGGIORNAMENTO	04	Rev.
	GEARS ENGRANAJES	ENGRANAGES ZAHNRÄDER		REVISION MISE A JOUR APLAZAMIENTO ANPASSUNG		2
				9/2000		

Pos.	Code	Q.ty	Description	Notes
58043086	58043086	0	SHOE	
58056391	58056391	0	SPRING	
59056365	59056365	0	PTO GEAR	
59056383	59056383	0	TRIPLE GEAR	

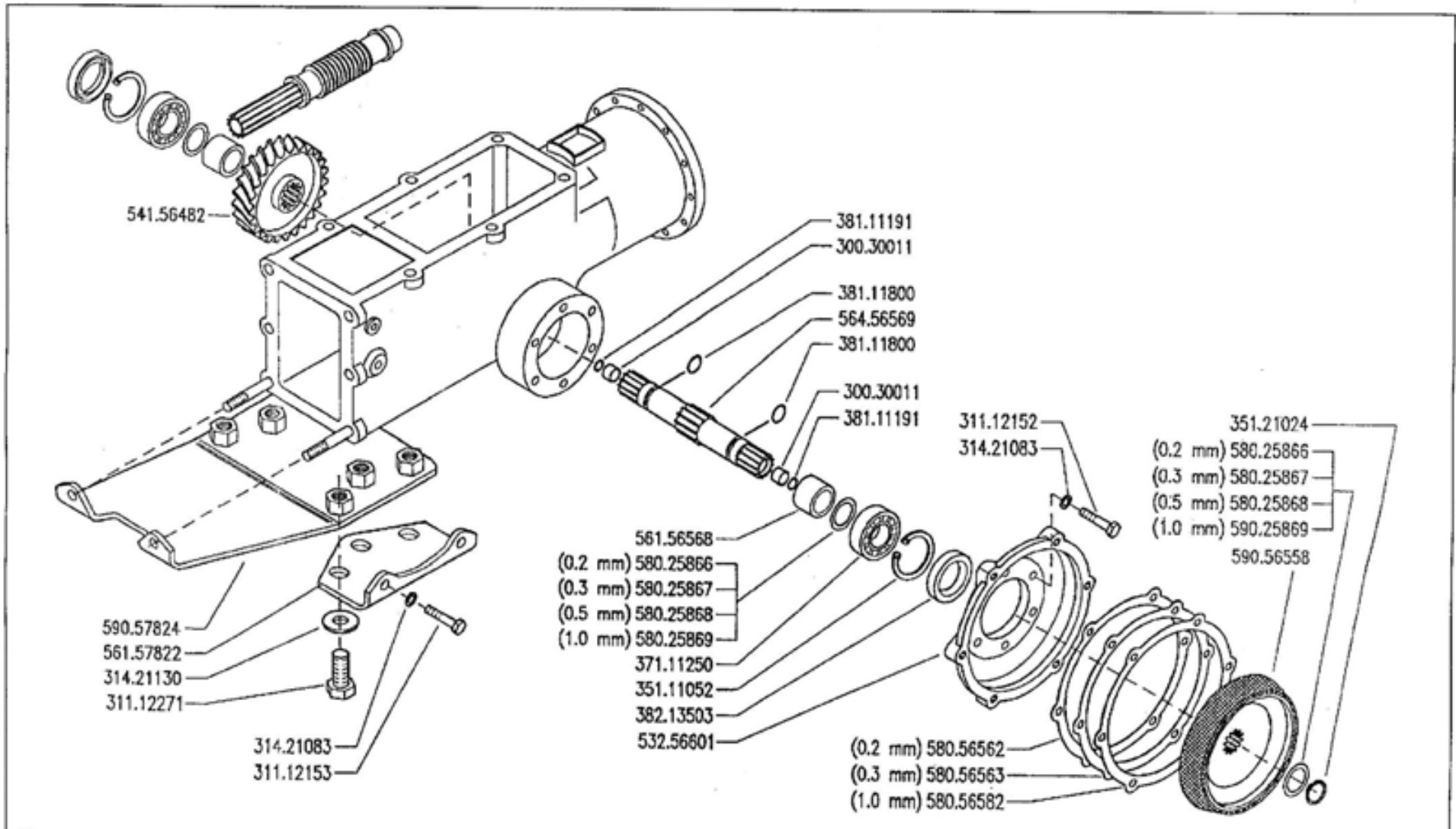

	500 serie 95	WHEEL AXLE EJE RUEDAS	ASSE RUOTE (530S2)	DALLA MACCHINA DE LA MAQUINA DE LA MACHINE FROM THE MACHINE AB DER MASCHINE	<input type="checkbox"/>	05 C 0	Rev. 0
					<input type="checkbox"/>		
					N.	4/2003	

Pos.	Code	Q.ty	Description	Notes
30030011	30030011	0	BUSHING 12X14X10	
31112152	31112152	0	SCREW TE M8X30 UNI 5739 8G	
31112153	31112153	0	SCREW TE M8X35 UNI 5739 8G	
31112271	31112271	0	SCREW TE M12X25 UNI 5739	
31421083	31421083	0	WASHER	
31421130	31421130	0	WASHER	
35111052	35111052	0	SEEGER RING I 52 DIN 472	
35121024	35121024	0	SEEGER RING E 24 DIN 471	
37111250	37111250	0	BEARING	
38111191	38111191	0	O-RING 115 (11,91X2,62)	
38111800	38111800	0	O-RING 4075 (18,64X3,53)	
38213503	38213503	0	OIL SEAL 35X52X8	
53256601	53256601	0	FLANGE	
54156482	54156482	0	CROWN WHEEL	
56156568	56156568	0	SPACER	
56157822	56157822	0	SQUARE	
56456569	56456569	0	OUTPUT SHAFT	
58025866	58025866	0	SHIM 0,2	
58025867	58025867	0	SHIM	
58025868	58025868	0	SHIM	
58025869	58025869	0	SHIM	
58056562	58056562	0	SHIM	
58056563	58056563	0	SHIM	
58056582	58056582	0	SHIM	
59056558	59056558	0	FRICITION CONE	
59057824	59057824	0	REINFORCED PLATE	

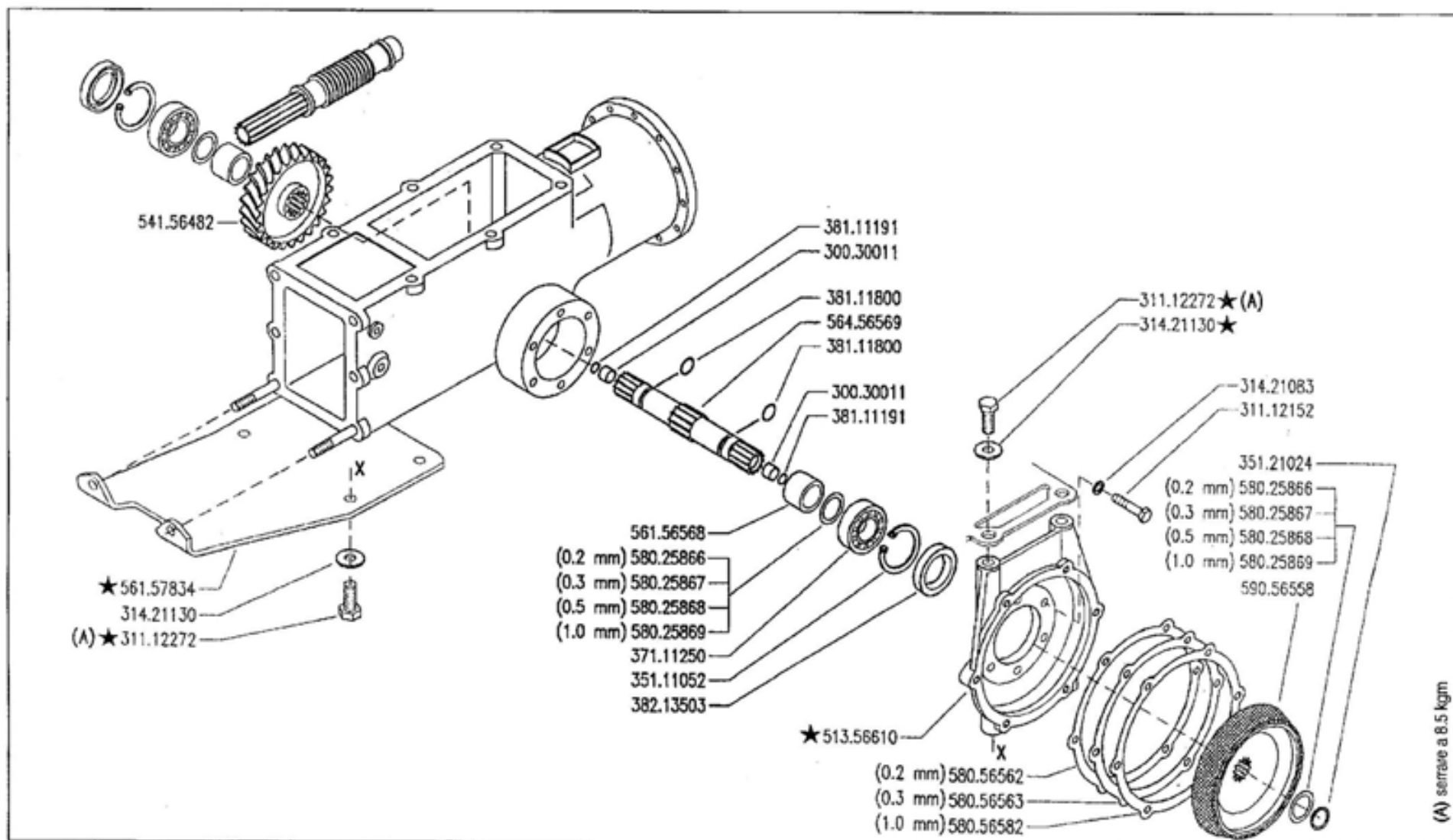

FERRARI	500 serie 95	WHEEL AXLE EJE RUEDAS	ASSE RUOTE (530S2)	ESSIEU ROUES RADACHSE	★ DALLA MACCHINA DE LA MAQUINA FROM THE MACHINE AB DER MASCHINE	ALLA MACCHINA A LA MAQUINA TO THE MACHINE BIS MASCHINE	05 C	Rev. 1
					721207 721255	721222		

(A) serrare a 8.5 kgm

Pos.	Code	Q.ty	Description	Notes
30030011	30030011	0	BUSHING 12X14X10	
31112152	31112152	0	SCREW TE M8X30 UNI 5739 8G	
31112272	31112272	0	SCREW TE M12X30 UNI 5739	
31421083	31421083	0	WASHER	
31421130	31421130	0	WASHER	
35111052	35111052	0	SEEGER RING I 52 DIN 472	
35121024	35121024	0	SEEGER RING E 24 DIN 471	
37111250	37111250	0	BEARING	
38111191	38111191	0	O-RING 115 (11,91X2,62)	
38111800	38111800	0	O-RING 4075 (18,64X3,53)	
38213503	38213503	0	OIL SEAL 35X52X8	
51356610	51356610	0	FLANGE	
54156482	54156482	0	CROWN WHEEL	
56156568	56156568	0	SPACER	
56157834	56157834	0	REINFORCED PLATE	
56456569	56456569	0	OUTPUT SHAFT	
58025866	58025866	0	SHIM 0,2	
58025867	58025867	0	SHIM	
58025868	58025868	0	SHIM	
58025869	58025869	0	SHIM	
58056562	58056562	0	SHIM	
58056563	58056563	0	SHIM	
58056582	58056582	0	SHIM	
59056558	59056558	0	FRICITION CONE	

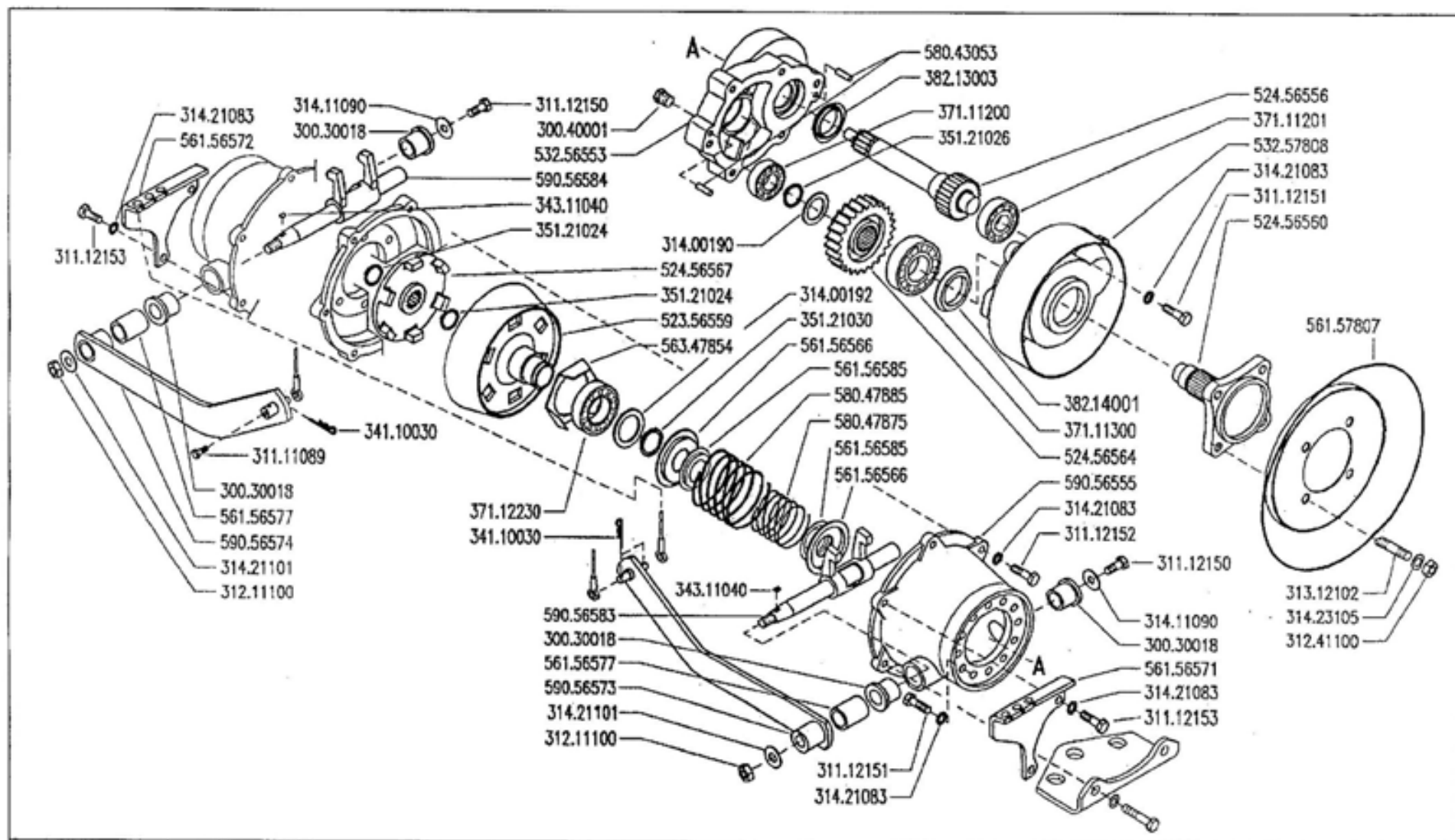

FERRARI

500 serie 95

WHEEL AXLE
EJE RUEDAS

ASSE RUOTE (530S2)

ESSIEU ROUES
RADACHSE

DALLA MACCHINA
DE LA MAQUINA
DE LA MACHINE
FROM THE MACHINE
AB DER MASCHINE

N.

05 D 0

Rev.

9/2002

2001

Pos.	Code	Q.ty	Description	Notes
30030018	30030018	0	BUSHING 18x25x25	
30040001	30040001	0	PLUG	
31111089	31111089	0	SCREW TE M5X10 UNI 5739 8G	
31112150	31112150	0	SCREW TE M8X20 UNI 5739 8G	
31112151	31112151	0	SCREW TE M8X25 UNI 5739 8G	
31112152	31112152	0	SCREW TE M8X30 UNI 5739 8G	
31112153	31112153	0	SCREW TE M8X35 UNI 5739 8G	
31211100	31211100	0	NUT M10	
31241100	31241100	0	SELFLOCK NUT M10 6S	
31312102	31312102	0	STUD BOLT M10X40X24X12	
31400190	31400190	0	SHIM	
31400192	31400192	0	SHIM PS 30x42/1,5	
31411090	31411090	0	WASHER 9x24	
31421083	31421083	0	WASHER	
31421101	31421101	0	WASHER	
31423105	31423105	0	SPRING WASHER 10,5	
34110030	34110030	0	SPLIT PIN	
34311040	34311040	0	KEY 4X6,5 UNI 6606	
35121024	35121024	0	SEEGER RING E 24 DIN 471	
35121026	35121026	0	SEEGER RING E 26 DIN 471	
35121030	35121030	0	SEEGER RING E 30 DIN 471	
37111200	37111200	0	BEARING	
37111201	37111201	0	BEARING	
37111300	37111300	0	BEARING	
37112230	37112230	0	BEARING	
38213003	38213003	0	OIL SEAL 30X47X7	
38214001	38214001	0	OIL SEAL 40X52X7	
52356559	52356559	0	FRICTION CONE	
52456556	52456556	0	SHAFT	
52456560	52456560	0	AXLE SHAFT	
52456564	52456564	0	GEAR	
52456567	52456567	0	DISC	
53256553	53256553	0	FLANGE	
53257808	53257808	0	COVER	

SERIAL

WHEEL AXLE (530S2)

CODE REV

05D_0_14243

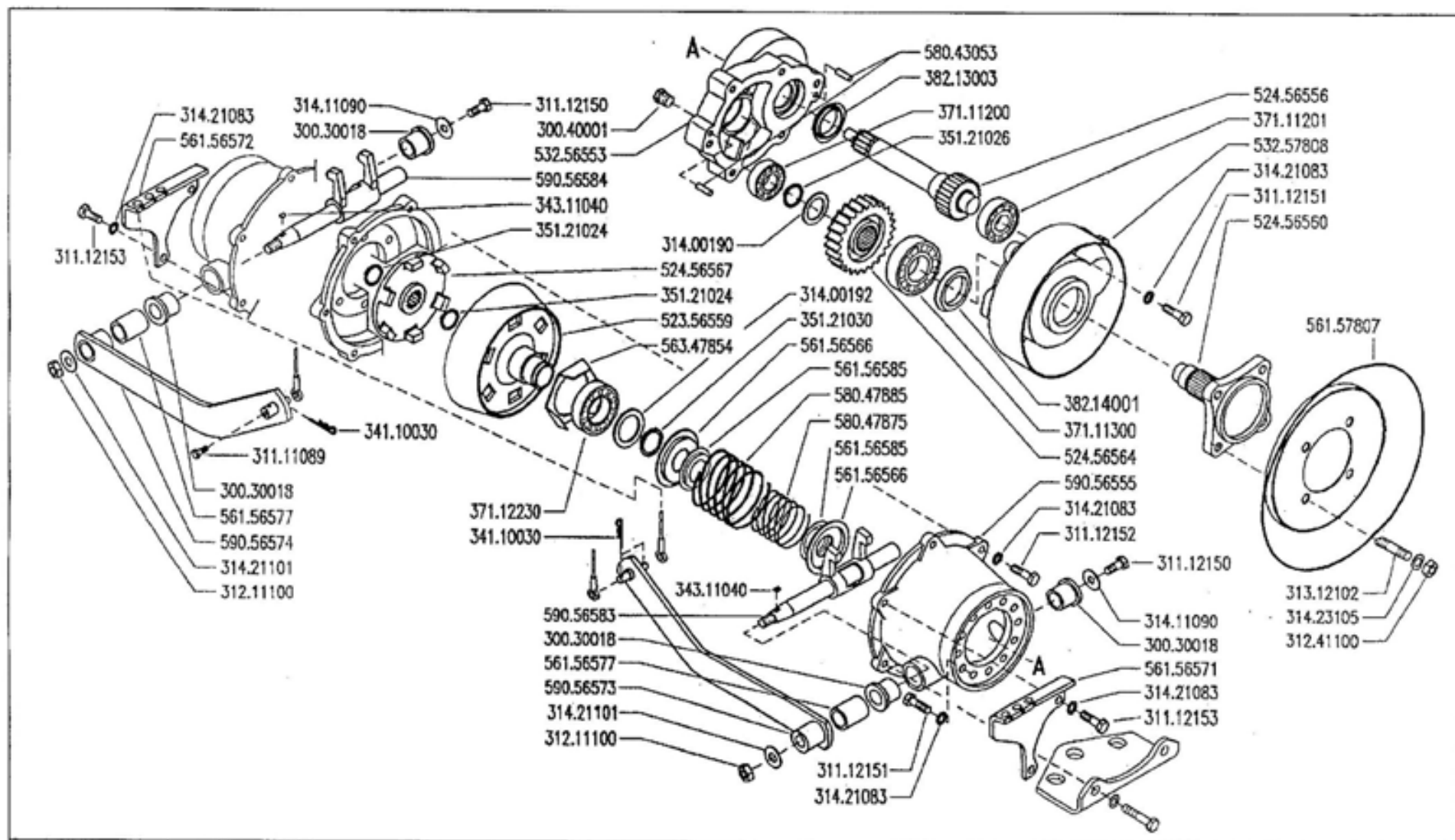

FERRARI

500 serie 95

ASSE RUOTE (530S2)

WHEEL AXLE
EJE RUEDAS

ESSIEU ROUES
RADACHSE

DALLA MACCHINA
DE LA MAQUINA
DE LA MACHINE
FROM THE MACHINE
AB DER MASCHINE

N.

05 D 0

Rev.

9/2002

2001

Pos.	Code	Q.ty	Description	Notes
56156566	56156566	0	STOP	
56156571	56156571	0	LEVER BEARING	
56156572	56156572	0	LEVER BEARING	
56156577	56156577	0	SPACER	
56156585	56156585	0	STOP	
56157807	56157807	0	BOTTOM	
56347854	56347854	0	GUARD	
58043053	58043053	0	CYLINDRICAL PLUG	
58047875	58047875	0	SPRING	
58047885	58047885	0	COUPLING SPRING	
59056555	59056555	0	CLUTCH HOUSING	
59056573	59056573	0	LEVER	
59056574	59056574	0	LEVER	
59056583	59056583	0	PIN	
59056584	59056584	0	PIN	

Pos.	Code	Q.ty	Description	Notes
30030018	30030018	0	BUSHING 18x25x25	
30040001	30040001	0	PLUG	
31111089	31111089	0	SCREW TE M5X10 UNI 5739 8G	
31112150	31112150	0	SCREW TE M8X20 UNI 5739 8G	
31112151	31112151	0	SCREW TE M8X25 UNI 5739 8G	
31112152	31112152	0	SCREW TE M8X30 UNI 5739 8G	
31112153	31112153	0	SCREW TE M8X35 UNI 5739 8G	
31211100	31211100	0	NUT M10	
31241100	31241100	0	SELFLOCK NUT M10 6S	
31312102	31312102	0	STUD BOLT M10X40X24X12	
31400190	31400190	0	SHIM	
31400192	31400192	0	SHIM PS 30x42/1,5	
31411090	31411090	0	WASHER 9x24	
31421083	31421083	0	WASHER	
31421101	31421101	0	WASHER	
31423105	31423105	0	SPRING WASHER 10,5	
34110030	34110030	0	SPLIT PIN	
34311040	34311040	0	KEY 4X6,5 UNI 6606	
35121024	35121024	0	SEEGER RING E 24 DIN 471	
35121026	35121026	0	SEEGER RING E 26 DIN 471	
35121030	35121030	0	SEEGER RING E 30 DIN 471	
37111200	37111200	0	BEARING	
37111201	37111201	0	BEARING	
37111300	37111300	0	BEARING	
37112230	37112230	0	BEARING	
38213003	38213003	0	OIL SEAL 30X47X7	
38214001	38214001	0	OIL SEAL 40X52X7	
52356559	52356559	0	FRICTION CONE	
52456556	52456556	0	SHAFT	
52456560	52456560	0	AXLE SHAFT	
52456564	52456564	0	GEAR	
52456567	52456567	0	DISC	
53256553	53256553	0	FLANGE	
53257808	53257808	0	COVER	

SERIAL

WHEEL AXLE (530S2)

CODE REV

05D_1_14293

Pos.	Code	Q.ty	Description	Notes
56156566	56156566	0	STOP	
56156571	56156571	0	LEVER BEARING	
56156572	56156572	0	LEVER BEARING	
56156577	56156577	0	SPACER	
56156585	56156585	0	STOP	
56157807	56157807	0	BOTTOM	
56347854	56347854	0	GUARD	
58043053	58043053	0	CYLINDRICAL PLUG	
58047875	58047875	0	SPRING	
58047885	58047885	0	COUPLING SPRING	
59056555	59056555	0	CLUTCH HOUSING	
59056573	59056573	0	LEVER	
59056574	59056574	0	LEVER	
59056583	59056583	0	PIN	
59056584	59056584	0	PIN	

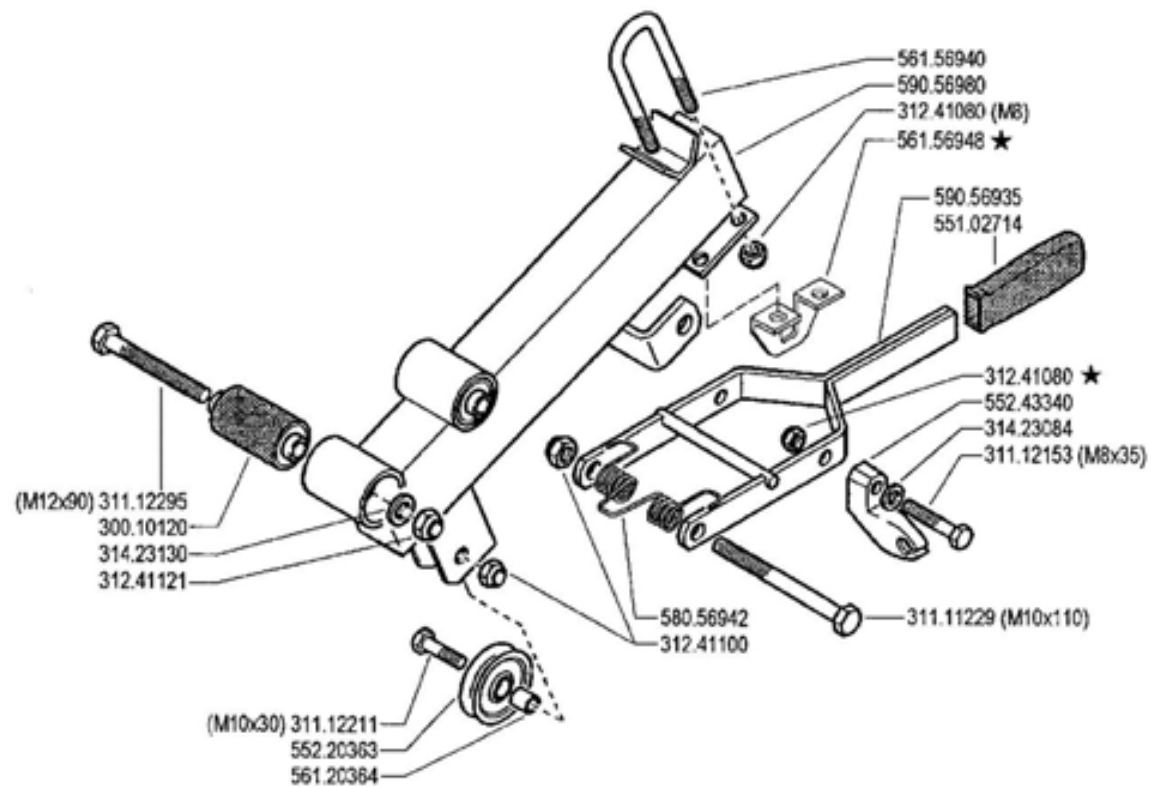

FERRARI

500 serie 95

PIANTONE (500 - 510 - 520 - 530 - 530S - 530S2)

STEERING COLUMN
COLUMNNA

PLANTON
LENKSÄULE

DALLA MACCHINA
DE LA MAQUINA
DE LA MACHINE
FROM THE MACHINE
AB DER MASCHINE

AGGIORNAMENTO

REVISION

MISE A JOUR

APLAZAMIENTO

ANPASSUNG

07

Rev.

3

12/2002

★N

3000

Pos.	Code	Q.ty	Description	Notes
30010120	30010120	0	SILENT-BLOCK 12X40X58X66	
31111229	31111229	0	SCREW TE M10X110 UNI 5737 8G	
31112153	31112153	0	SCREW TE M8X35 UNI 5739 8G	
31112211	31112211	0	SCREW TE M10X30 UNI 5739	
31112295	31112295	0	SCREW TE M12X90 UNI 5737	
31241080	31241080	0	SELFLOCK NUT M8	
31241100	31241100	0	SELFLOCK NUT M10 6S	
31241121	31241121	0	SELFLOCK NUT M12	
31423084	31423084	0	SPRING WASHER 8,4	
31423130	31423130	0	SPRING WASHER 13	
55102714	55102714	0	KNOB	
55220363	55220363	0	PULLEY	
55243340	55243340	0	SUPPORT	
56120364	56120364	0	SLEEVE	
56156940	56156940	0	U BOLT	
56156948	56156948	0	STOP	
58056942	58056942	0	SPRING	
59056935	59056935	0	LEVER	
59056980	59056980	0	COLUMN	

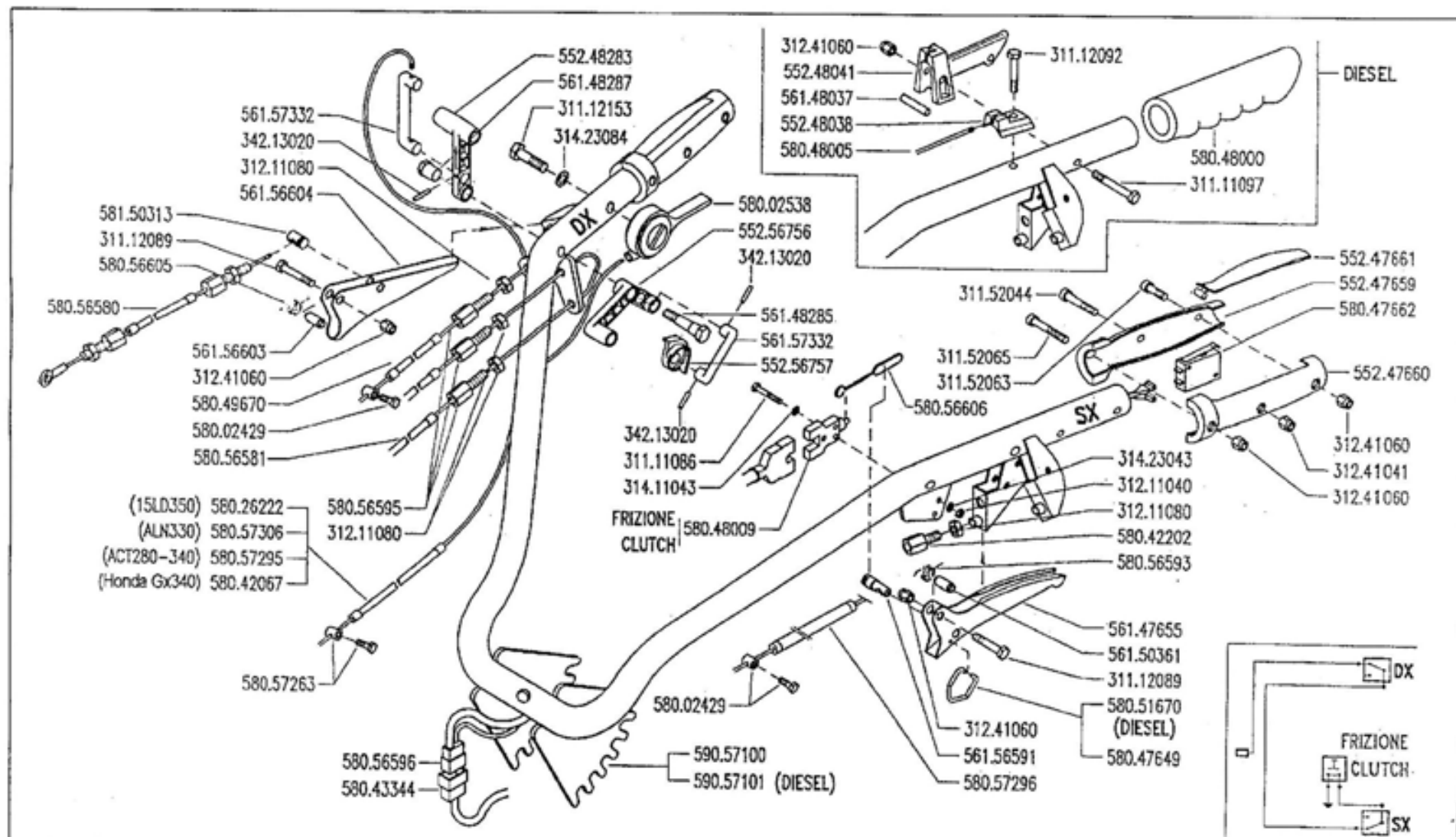

FERRARI

500 serie 95

MANUBRIO (530S2)

HANDLEBAR (530S2)
MANILLAR (530S2)

MANCHERON (530S2)
LENKER (530S2)

DALLA MACCHINA
DE LA MAQUINA
DE LA MACHINE
FROM THE MACHINE
AB DER MASCHINE

N.

08 C 0

12/2002

Rev.

12/02

Pos.	Code	Q.ty	Description	Notes
31111086	31111086	0	SCREW TE M4X25 UNI 5739 8G	
31111097	31111097	0	SCREW TE M6X45 UNI 5737 8G	
31112089	31112089	0	SCREW TE M6X25 UNI 5739 8G	
31112092	31112092	0	SCREW TE M6X35 UNI 5739 8G	
31112153	31112153	0	SCREW TE M8X35 UNI 5739 8G	
31152044	31152044	0	SCREW TCEI M4X35 UNI 5931	
31152063	31152063	0	SCREW TCEI M6X20 UNI 5931	
31152065	31152065	0	SCREW TCEI M6X40 UNI 5931	
31211040	31211040	0	NUT M4	
31211080	31211080	0	NUT M8	
31241041	31241041	0	SELFLOCK NUT M4 6S	
31241060	31241060	0	SELFLOCK NUT M6	
31411043	31411043	0	WASHER 4,3X9	
31423043	31423043	0	SPRING WASHER 4,3	
31423084	31423084	0	SPRING WASHER 8,4	
34213020	34213020	0	ROLL PIN	
55247659	55247659	0	HALK KNOB	
55247660	55247660	0	HALK KNOB	
55247661	55247661	0	KEY	
55248038	55248038	0	STOP	
55248041	55248041	0	LEVER	
55248283	55248283	0	COMMAND LEVER	
55256756	55256756	0	COMMAND LEVER	
55256757	55256757	0	PULLEY	
56147655	56147655	0	CLUTCH LEVER	
56148037	56148037	0	LEVER STOP	
56148285	56148285	0	PIN	
56148287	56148287	0	STUD BOLT	
56150361	56150361	0	SPACER	
56156591	56156591	0	CABLE CLAMP	
56156603	56156603	0	SPACER	
56156604	56156604	0	CLUTCH LEVER	
56157332	56157332	0	U BOLT	
58002429	58002429	0	CLAMPING SCREW	

SERIAL

HANDLEBAR (530S2)

CODE REV

08C_0_14518

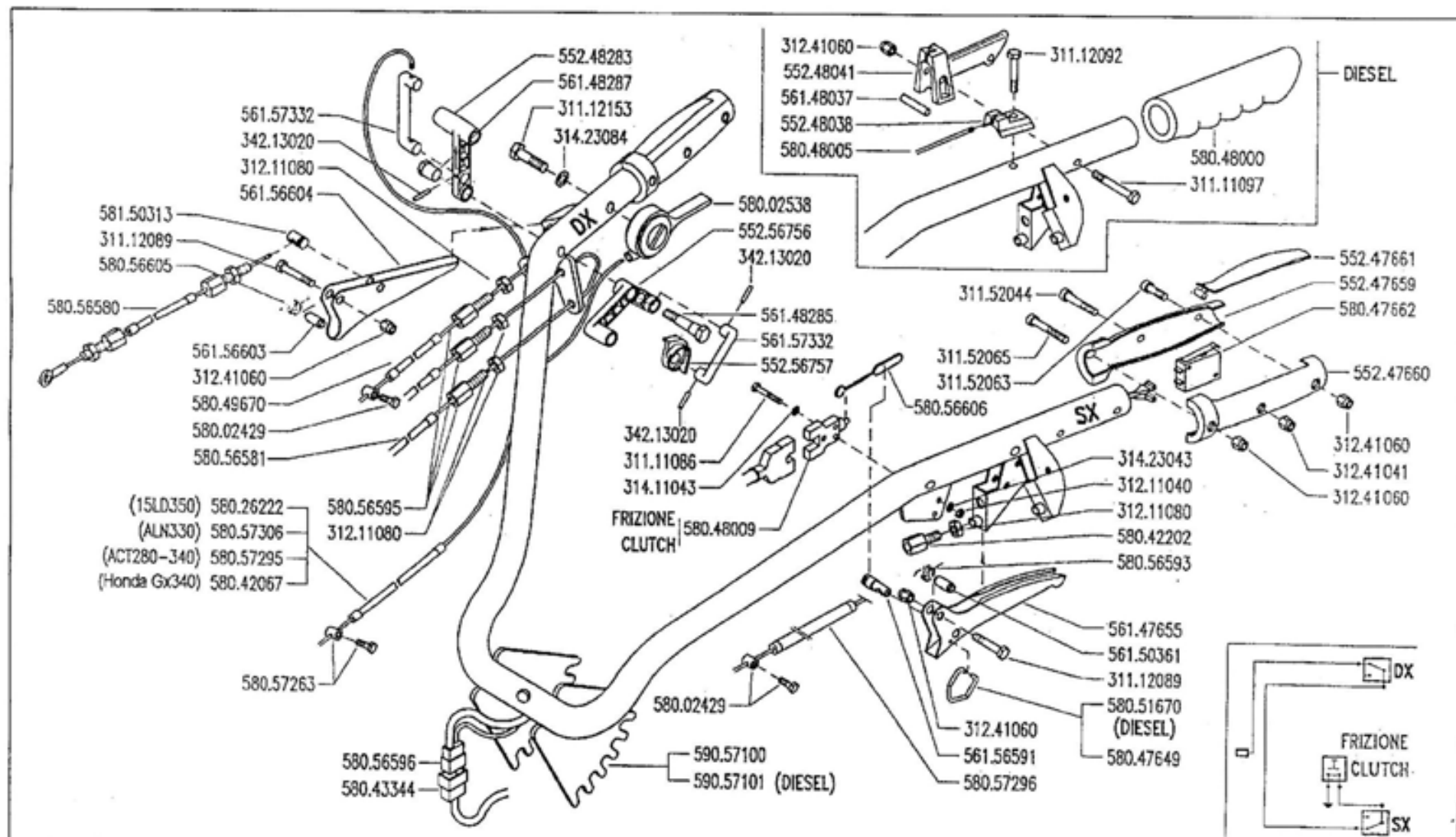

FERRARI

500 serie 95

MANUBRIO (530S2)

HANDLEBAR (530S2)
MANILLAR (530S2)

MANCHERON (530S2)
LENKER (530S2)

DALLA MACCHINA
DE LA MAQUINA
DE LA MACHINE
FROM THE MACHINE
AB DER MASCHINE

N.

08 C 0

12/2002

Rev.

12/02

Pos.	Code	Q.ty	Description	Notes
58002538	58002538	0	COMMAND LEVER	
58026222	58026222	0	LINE AND SHEATH	
58042067	58042067	0	LINE AND SHEATH	
58042202	58042202	0	ADJUSTING SCREW	
58043344	58043344	0	WIRING	
58047649	58047649	0	CLEVIS	
58047662	58047662	0	MICROSWITCH	
58048000	58048000	0	KNOB	
58048005	58048005	0	LINE AND SHEATH	
58048009	58048009	0	SWITCH	
58049670	58049670	0	LINE AND SHEATH	
58051670	58051670	0	CLEVIS	
58056580	58056580	0	TRANSMISSION	
58056581	58056581	0	LINE AND SHEATH	
58056593	58056593	0	SPRING	
58056595	58056595	0	ADJUSTING SCREW	
58056596	58056596	0	WIRING	
58056605	58056605	0	SPRING	
58056606	58056606	0	SPRING	
58057263	58057263	0	CLAMPING SCREW	
58057295	58057295	0	LINE AND SHEATH	
58057296	58057296	0	LINE AND SHEATH	
58057306	58057306	0	LINE AND SHEATH	
58150313	58150313	0	CABLE CLAMP	
59057100	59057100	0	COMPLETE HANDLE BAR	
59057101	59057101	0	COMPLETE HANDLE BAR	

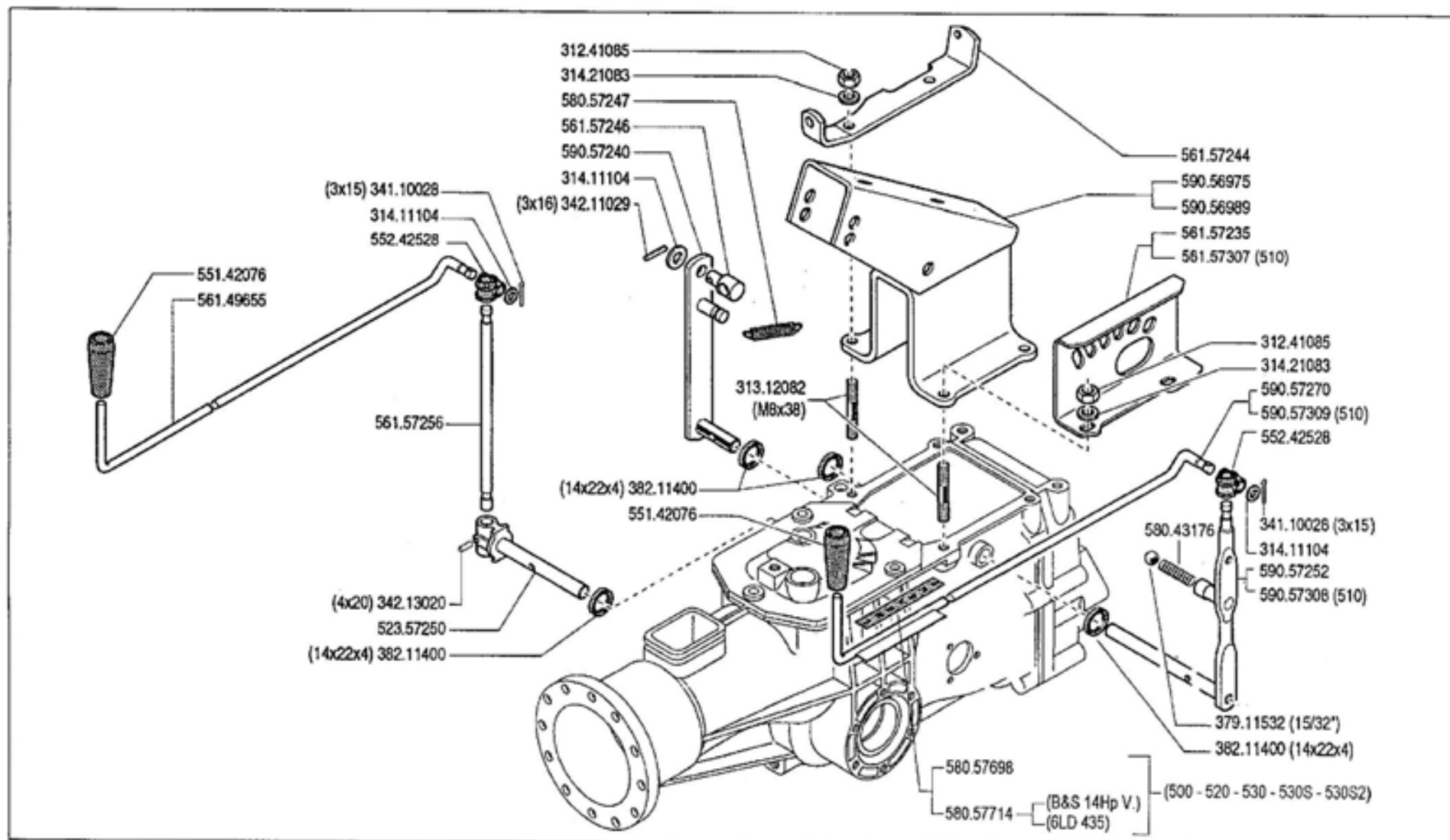

FERRARI

500 serie **95**

COMANDI (500 - 510 - 520 - 530 - 530S★ - 530S2★)

CONTROLS
MANDOS

COMMANDES
ANTRIEBE

DALLA MACCHINA
DE LA MAQUINA
FROM THE MACHINE
AB DER MASCHINE

AGGIORNAMENTO

REVISION

MISE A JOUR

APLAZAMIENTO

ANPASSUNG

09

Rev.
3

10/2001

★N.

3/2001

Pos.	Code	Q.ty	Description	Notes
31241085	31241085	0	SELFLOCK NUT M8 6S	
31312082	31312082	0	STUD BOLT M8X38X14X20	
31411104	31411104	0	WASHER 10,5x18	
31421083	31421083	0	WASHER	
34110028	34110028	0	SPLIT PIN	
34211029	34211029	0	ROLL PIN	
34213020	34213020	0	ROLL PIN	
37911532	37911532	0	BALL 15/32	
38211400	38211400	0	OIL SEAL 14X22X4	
52357250	52357250	0	PIN	
55142076	55142076	0	KNOB	
55242528	55242528	0	JOINT	
56149655	56149655	0	PULL ROD	
56157235	56157235	0	GEAR SELECTOR	
56157244	56157244	0	STOP	
56157246	56157246	0	STOP	
56157256	56157256	0	PTO LEVER	
56157307	56157307	0	SELECTOR	
58043176	58043176	0	SPRING	
58057247	58057247	0	SPRING	
58057698	58057698	0	DECAL	
58057714	58057714	0	DECAL	
59056975	59056975	0	SUPPORT	
59056989	59056989	0	SUPPORT	
59057240	59057240	0	LEVER	
59057252	59057252	0	GEAR LEVER	
59057270	59057270	0	GEARSHIFT ROD	
59057308	59057308	0	GEAR LEVER	
59057309	59057309	0	GEARSHIFT ROD	

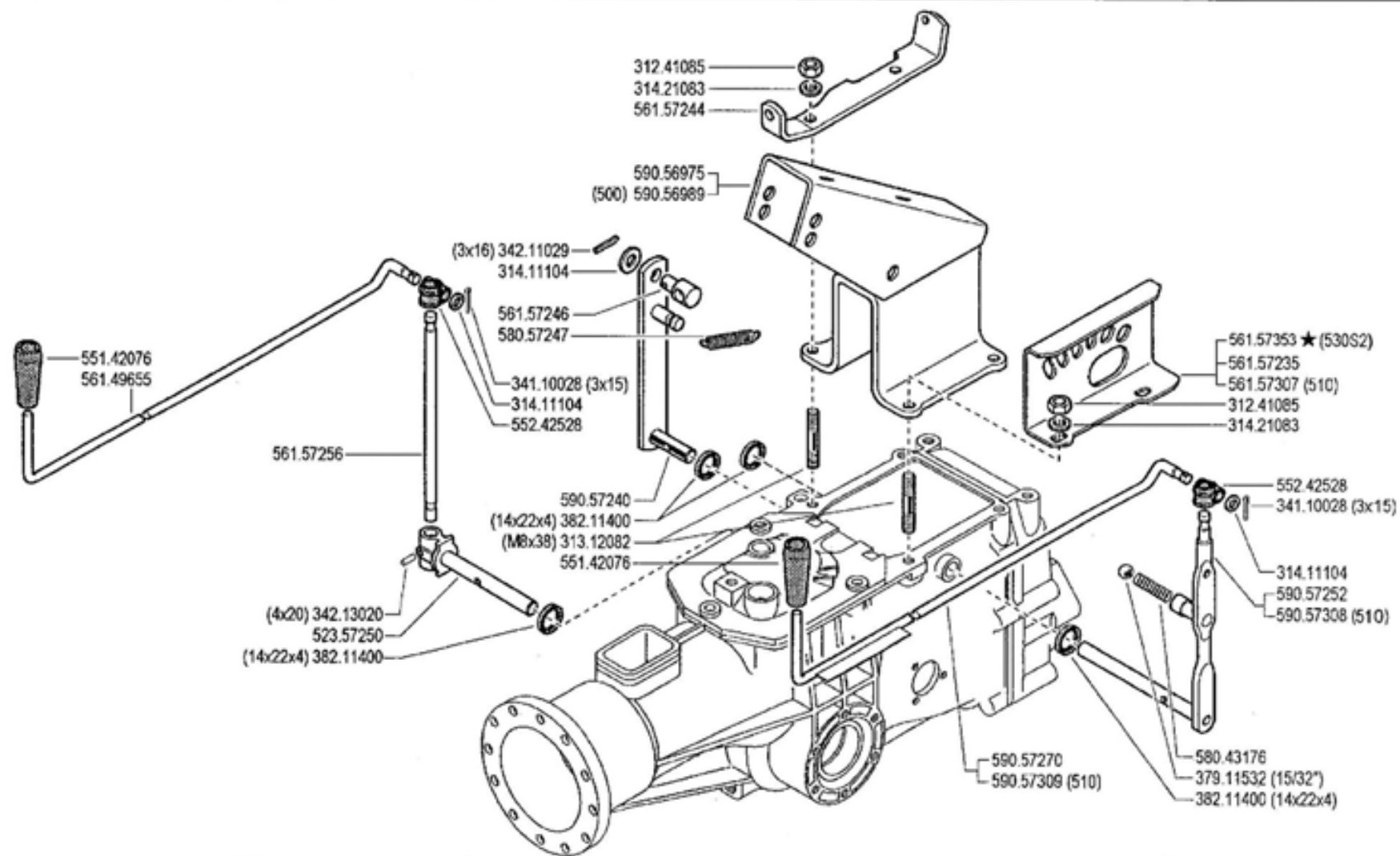

FERRARI

500 serie **95**

COMANDI (500 - 510 - 520 - 530 - 530S2)

CONTROLS
MANDOS

COMMANDES
ANTRIEBE

★ DALLA MACCHINA
DE LA MAQUINA
DE LA MACHINE
FROM THE MACHINE
AB DER MASCHINE

ALLA MACCHINA
A LA MAQUINA
A LA MACHINE
TO THE MACHINE
BIS MASCHINE

09

Rev.
4

N. 721207
721255

721222

1/2004

1/2004

Pos.	Code	Q.ty	Description	Notes
31241085	31241085	0	SELFLOCK NUT M8 6S	
31312082	31312082	0	STUD BOLT M8X38X14X20	
31411104	31411104	0	WASHER 10,5x18	
31421083	31421083	0	WASHER	
34110028	34110028	0	SPLIT PIN	
34211029	34211029	0	ROLL PIN	
34213020	34213020	0	ROLL PIN	
37911532	37911532	0	BALL 15/32	
38211400	38211400	0	OIL SEAL 14X22X4	
52357250	52357250	0	PIN	
55142076	55142076	0	KNOB	
55242528	55242528	0	JOINT	
56149655	56149655	0	PULL ROD	
56157235	56157235	0	GEAR SELECTOR	
56157244	56157244	0	STOP	
56157246	56157246	0	STOP	
56157256	56157256	0	PTO LEVER	
56157307	56157307	0	SELECTOR	
56157353	56157353	0	GEAR SELECTOR	
58043176	58043176	0	SPRING	
58057247	58057247	0	SPRING	
59056975	59056975	0	SUPPORT	
59056989	59056989	0	SUPPORT	
59057240	59057240	0	LEVER	
59057252	59057252	0	GEAR LEVER	
59057270	59057270	0	GEARSHIFT ROD	
59057308	59057308	0	GEAR LEVER	
59057309	59057309	0	GEARSHIFT ROD	

SERIAL

CONTROLS(500/10/20-530-530S2)

CODE REV

009_4_13594

	A	B	C
3.50 - 8" (500)	391.13502	394.13502	580.52325
3.50 - 8"	391.13502	394.13502	580.52326
4.00 - 8"	391.14008	394.14008	580.52326
4.0 - 10"	391.14010	394.14010	580.52327
5.0 - 10"	391.15010	394.15010	580.52327
21 x 11.00 - 8"	391.13501	TUBELESS	580.52274 ★ (1)

★ 924.57794

KIT GEMELLAGGIO PER 4.0-10" / 5.0-10"
 TWINNING KIT FOR 4.0-10" / 5.0-10"
 JUMELAGE KIT POUR 4.0-10" / 5.0-10"
 KIT GEMELOS POR 4.0-10" / 5.0-10"
 ZWILLINGSKIT 4.0-10" / 5.0-10"

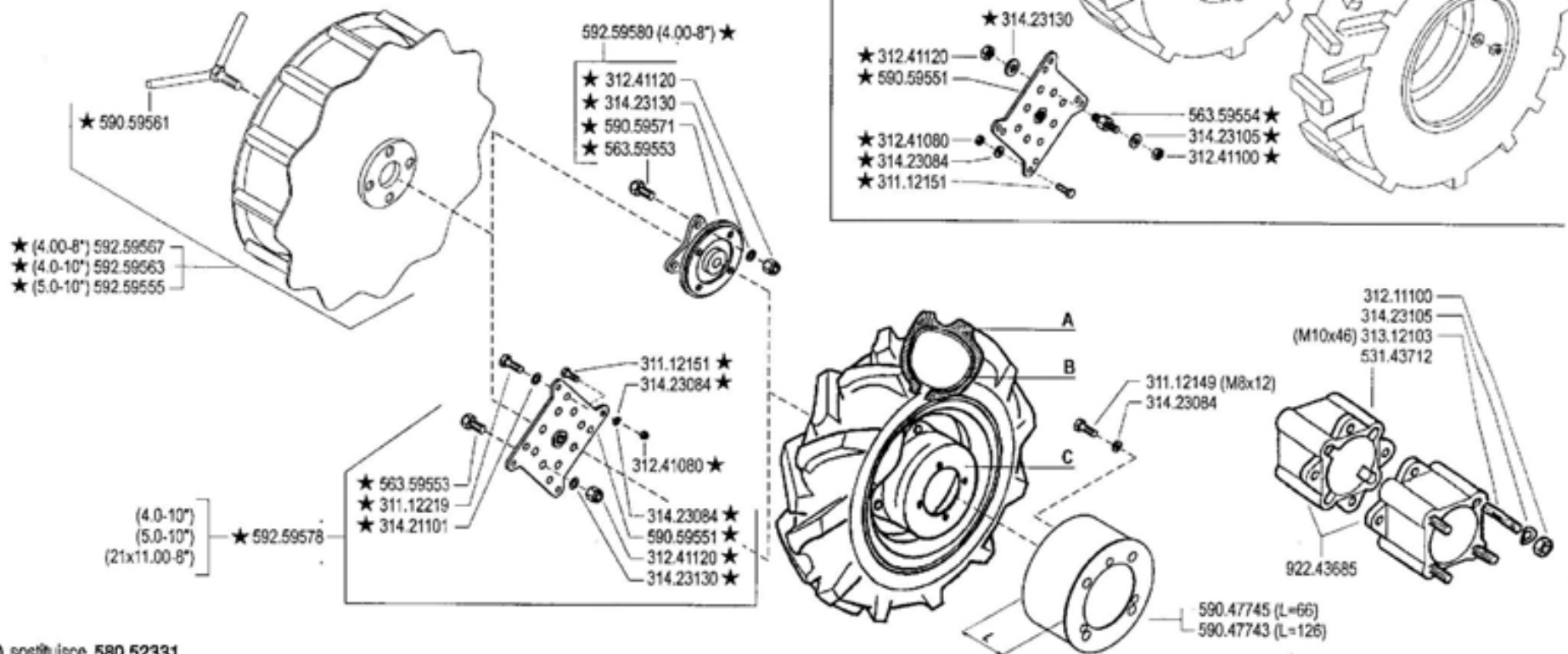

(1) sostituisce 580.52331

FERRARI

500 serie 95

RUOTE

WHEELS
 RUEDAS

ROUES
 RÄDER

DALLA MACCHINA
 DE LA MAQUINA
 DE LA MACHINE
 FROM THE MACHINE
 AB DER MASCHINE

AGGIORNAMENTO

REVISION

MISE A JOUR

APLAZAMIENTO

ANPASSUNG

11

Rev.
 3

12/2003

★ N.

71/06

Pos.	Code	Q.ty	Description	Notes
31112149	31112149	0	SCREW TE M8X12 UNI 5739 8G	
31112151	31112151	0	SCREW TE M8X25 UNI 5739 8G	
31112219	31112219	0	SCREW TE M10X25 UNI 5739	
31211100	31211100	0	NUT M10	
31241080	31241080	0	SELFLOCK NUT M8	
31241100	31241100	0	SELFLOCK NUT M10 6S	
31241120	31241120	0	SELFLOCK NUT M12	
31312103	31312103	0	STUD BOLT M10X46X24X16	
31421101	31421101	0	WASHER	
31423084	31423084	0	SPRING WASHER 8,4	
31423105	31423105	0	SPRING WASHER 10,5	
31423130	31423130	0	SPRING WASHER 13	
39113501	39113501	0	TYRE 21X11.00-8	
39113502	39113502	0	TYRE 3.50-8 2PR	
39114008	39114008	0	TYRE 4.00-8 2PR	
39114010	39114010	0	TYRE 4.0-10 2PR	
39115010	39115010	0	TYRE 5.00-10 2PR	
39413502	39413502	0	INNER TUBE	
39414008	39414008	0	INNER TUBE	
39414010	39414010	0	INNER TUBE	
39415010	39415010	0	INNER TUBE	
53143712	53143712	0	SPACER	
56359553	56359553	0	PIN	
56359554	56359554	0	PIN	
58052274	58052274	0	RIM	
58052325	58052325	0	RIM	
58052326	58052326	0	RIM	
58052327	58052327	0	RIM	
59047743	59047743	0	HUBCOVER	
59047745	59047745	0	HUBCOVER	
59059551	59059551	0	FLANGE	
59059561	59059561	0	SCREW	
59059571	59059571	0	FLANGE	
59259555	59259555	0	SUPER-BITE WHEEL X 5.00-10	

SERIAL

WHEELS

CODE REV

011_3_13744

	A	B	C
3.50 - 8" (500)	391.13502	394.13502	580.52325
3.50 - 8"	391.13502	394.13502	580.52326
4.00 - 8"	391.14008	394.14008	580.52326
4.0 - 10"	391.14010	394.14010	580.52327
5.0 - 10"	391.15010	394.15010	580.52327
21 x 11.00 - 8"	391.13501	TUBELESS	580.52274 ★ (1)

★ 924.57794

KIT GEMELLAGGIO PER 4.0-10" / 5.0-10"
 TWINNING KIT FOR 4.0-10" / 5.0-10"
 JUMELAGE KIT POUR 4.0-10" / 5.0-10"
 KIT GEMELOS POR 4.0-10" / 5.0-10"
 ZWILLINGSKIT 4.0-10" / 5.0-10"

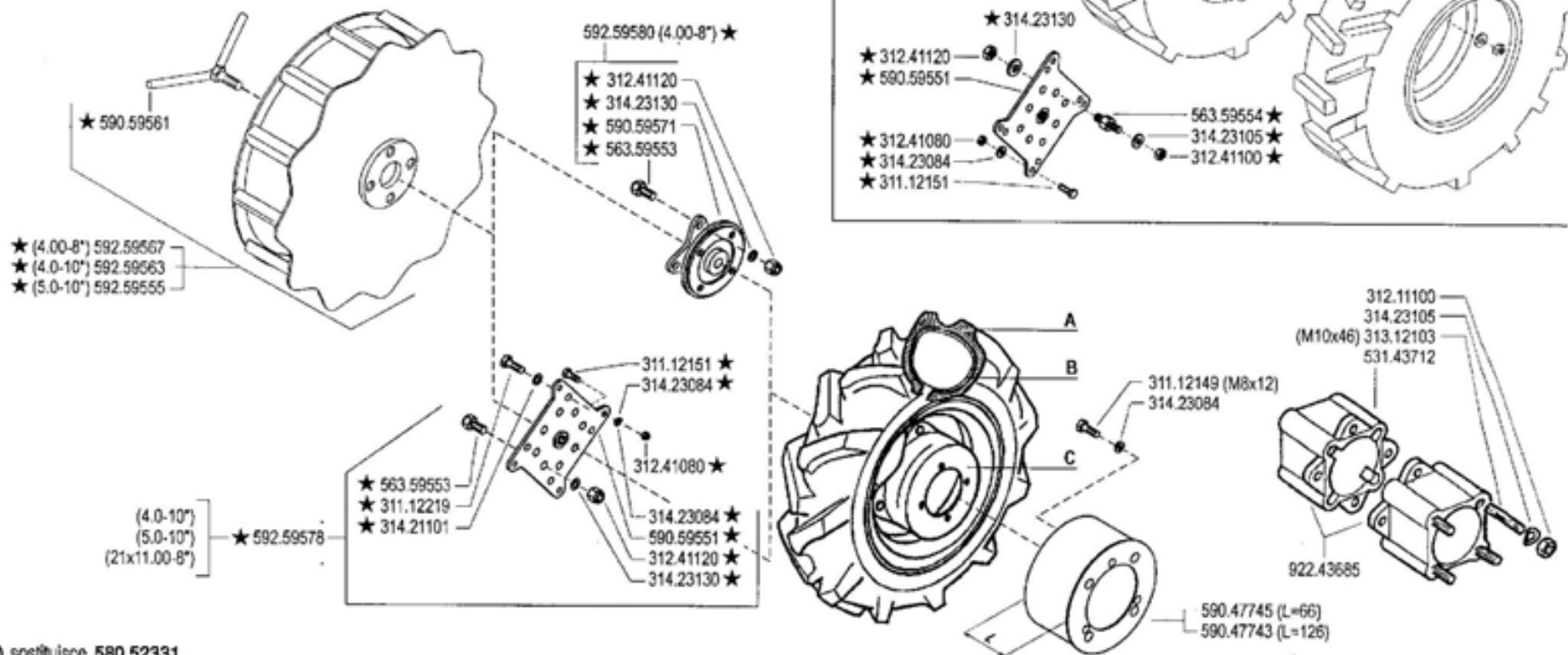

(1) sostituisce 580.52331

FERRARI

500 serie 95

RUOTE

WHEELS
 RUEDAS

ROUES
 RÄDER

DALLA MACCHINA
 DE LA MAQUINA
 DE LA MACHINE
 FROM THE MACHINE
 AB DER MASCHINE

AGGIORNAMENTO
 REVISION
 MISE A JOUR
 APLAZAMIENTO
 ANPASSUNG

11

Rev.
 3

12/2003

★ N.

71/06

Pos.	Code	Q.ty	Description	Notes
59259563	59259563	0	WHEEL	
59259567	59259567	0	WHEEL	
59259578	59259578	0	FLANGE KIT	
59259580	59259580	0	FLANGE KIT	
92243685	92243685	0	PAIR WHEEL SPACERS 6 CM	
92457794	92457794	0	ADAPTOR PLATES 10 WHEELS (PAIR)	

510

580.52033

510

580.52034



580.52019 (L= 87)
580.52029 (L= 140)
580.52020 (L= 174)

515

580.52144

515

580.52145

520

580.52021

520

580.52022

500

580.52018

530

580.52023

530

580.52024

515 L

580.52146

530 S

580.52150 ★

530 S

580.52151 ★

515 L

580.52147

530 S2

580.52154 ★

530 S2

580.52155 ★

515 S

580.52148

515 S

580.52149

FERRARI

500 serie 95

ADESIVI

STICKERS
ADHESIVOS

AUTOCOLLANTS
AUFKLEBES

DALLA MACCHINA
DE LA MAQUINA
DE LA MACHINE
FROM THE MACHINE
AB DER MASCHINE

★N.

AGGIORNAMENTO

REVISION

MISE A JOUR

APLAZAMIENTO

ANPASSUNG

12

Rev.
2

10/2001

22/01/01

Pos.	Code	Q.ty	Description	Notes
58052018	58052018	0	DECAL	
58052019	58052019	0	DECAL	
58052020	58052020	0	DECAL	
58052021	58052021	0	DECAL	
58052022	58052022	0	DECAL	
58052023	58052023	0	DECAL	
58052024	58052024	0	DECAL	
58052029	58052029	0	DECAL	
58052033	58052033	0	DECAL	
58052034	58052034	0	DECAL	
58052144	58052144	0	DECAL	
58052145	58052145	0	DECAL	
58052146	58052146	0	DECAL	
58052147	58052147	0	DECAL	
58052148	58052148	0	DECAL	
58052149	58052149	0	DECAL	
58052150	58052150	0	DECAL	
58052151	58052151	0	DECAL	
58052154	58052154	0	DECAL	
58052155	58052155	0	DECAL	



580.57698



580.46912



580.46913



580.57772 ★



580.57771 ★



580.57767 ★



580.57768 ★



580.57678



580.57712



580.57676

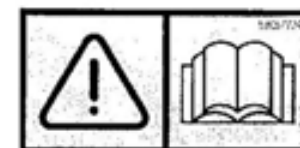

580.57724

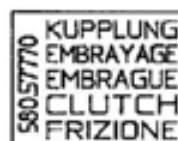

580.57770 ★



580.57722

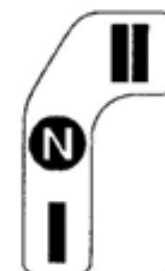

580.57732

FERRARI

500 serie 95

ADESIVI

STICKERS
ADHESIVOS

AUTOCOLLANTS
AUFKLEBES

DALLA MACCHINA
DE LA MAQUINA
DE LA MACHINE
FROM THE MACHINE
AB DER MASCHINE

AGGIORNAMENTO

REVISION

MISE A JOUR

APLAZAMIENTO

ANPASSUNG

13

Rev.
1

12/2003

★N

F004

Pos.	Code	Q.ty	Description	Notes
58046912	58046912	0	DECAL	
58046913	58046913	0	DECAL	
58057676	58057676	0	DECAL	
58057678	58057678	0	DECAL	
58057698	58057698	0	DECAL	
58057712	58057712	0	DECAL	
58057722	58057722	0	DECAL	
58057724	58057724	0	DECAL	
58057732	58057732	0	DECAL	
58057767	58057767	0	DECAL	
58057768	58057768	0	DECAL	
58057770	58057770	0	DECAL	
58057771	58057771	0	DECAL	
58057772	58057772	0	DECAL	

SPARE PARTS INSTANCE INDEX





SPARE PARTS INSTANCE INDEX

Code	Parts Table	Pos.	Q.ty	Code	Parts Table	Pos.	Q.ty	Code	Parts Table	Pos.	Q.ty
30010120	007_3_13177	30010120	0	31112153	05D_1_14293	31112153	0	31241100	007_3_13177	31241100	0
30030011	05C_0_14191	30030011	0		08C_0_14518	31112153	0		011_3_13744	31241100	0
	05C_1_14218	30030011	0	31112154	001_4_12698	31112154	0		05D_0_14243	31241100	0
30030018	05D_0_14243	30030018	0	31112211	004_2_12967	31112211	0		05D_1_14293	31241100	0
	05D_1_14293	30030018	0		007_3_13177	31112211	0	31241120	011_3_13744	31241120	0
30040001	003_1_12834	30040001	0	31112213	001_4_12698	31112213	0	31241121	007_3_13177	31241121	0
	03B_0_13977	30040001	0	31112219	011_3_13744	31112219	0	31312078	03B_0_13977	31312078	0
	05D_0_14243	30040001	0	31112271	05C_0_14191	31112271	0	31312082	003_1_12834	31312082	0
	05D_1_14293	30040001	0	31112272	05C_1_14218	31112272	0		009_3_13564	31312082	0
31111086	08C_0_14518	31111086	0	31112295	007_3_13177	31112295	0		009_4_13594	31312082	0
31111089	05D_0_14243	31111089	0	31121007	001_4_12698	31121007	0	31312084	003_1_12834	31312084	0
	05D_1_14293	31111089	0	31152044	08C_0_14518	31152044	0		03B_0_13977	31312084	0
31111090	003_1_12834	31111090	0	31152063	08C_0_14518	31152063	0	31312085	003_1_12834	31312085	0
	03B_0_13977	31111090	0	31152065	08C_0_14518	31152065	0		03B_0_13977	31312085	0
31111097	08C_0_14518	31111097	0	31152103	003_1_12834	31152103	0	31312088	03B_0_13977	31312088	0
31111151	001_4_12698	31111151	0	31211040	08C_0_14518	31211040	0	31312094	003_1_12834	31312094	0
31111229	007_3_13177	31111229	0	31211080	08C_0_14518	31211080	0	31312102	05D_0_14243	31312102	0
31112089	08C_0_14518	31112089	0	31211100	011_3_13744	31211100	0		05D_1_14293	31312102	0
31112092	08C_0_14518	31112092	0		05D_0_14243	31211100	0	31312103	011_3_13744	31312103	0
31112149	011_3_13744	31112149	0		05D_1_14293	31211100	0	31312124	003_1_12834	31312124	0
31112150	001_4_12698	31112150	0	31221121	003_1_12834	31221121	0	31312125	003_1_12834	31312125	0
	05D_0_14243	31112150	0		03B_0_13977	31221121	0		03B_0_13977	31312125	0
	05D_1_14293	31112150	0	31241041	08C_0_14518	31241041	0	31400190	05D_0_14243	31400190	0
31112151	003_1_12834	31112151	0	31241060	08C_0_14518	31241060	0		05D_1_14293	31400190	0
	011_3_13744	31112151	0	31241080	001_4_12698	31241080	0	31400192	05D_0_14243	31400192	0
	05D_0_14243	31112151	0		003_1_12834	31241080	0		05D_1_14293	31400192	0
	05D_1_14293	31112151	0		007_3_13177	31241080	0	31411043	08C_0_14518	31411043	0
31112152	05C_0_14191	31112152	0		011_3_13744	31241080	0	31411084	001_4_12698	31411084	0
	05C_1_14218	31112152	0		03B_0_13977	31241080	0	31411090	05D_0_14243	31411090	0
	05D_0_14243	31112152	0	31241085	003_1_12834	31241085	0		05D_1_14293	31411090	0
	05D_1_14293	31112152	0		009_3_13564	31241085	0	31411104	001_4_12698	31411104	0
31112153	007_3_13177	31112153	0		009_4_13594	31241085	0		009_3_13564	31411104	0
	05C_0_14191	31112153	0		03B_0_13977	31241085	0		009_4_13594	31411104	0
	05D_0_14243	31112153	0	31241100	001_4_12698	31241100	0	31421083	001_4_12698	31421083	0



SPARE PARTS INSTANCE INDEX

Code	Parts Table	Pos.	Q.ty	Code	Parts Table	Pos.	Q.ty	Code	Parts Table	Pos.	Q.ty
31421083	003_1_12834	31421083	0	34211029	009_3_13564	34211029	0	37111300	05D_1_14293	37111300	0
	009_3_13564	31421083	0		009_4_13594	34211029	0	37112229	004_2_12967	37112229	0
	009_4_13594	31421083	0	34211042	004_2_12967	34211042	0	37112230	05D_0_14243	37112230	0
	03B_0_13977	31421083	0	34213020	009_3_13564	34213020	0		05D_1_14293	37112230	0
	05C_0_14191	31421083	0		009_4_13594	34213020	0	37320120	004_2_12967	37320120	0
	05C_1_14218	31421083	0		08C_0_14518	34213020	0	37910832	004_2_12967	37910832	0
	05D_0_14243	31421083	0	34213060	004_2_12967	34213060	0	37911532	009_3_13564	37911532	0
	05D_1_14293	31421083	0	34213061	004_2_12967	34213061	0		009_4_13594	37911532	0
31421101	004_2_12967	31421101	0	34311040	05D_0_14243	34311040	0	38111191	05C_0_14191	38111191	0
	011_3_13744	31421101	0		05D_1_14293	34311040	0		05C_1_14218	38111191	0
	05D_0_14243	31421101	0	35111052	05C_0_14191	35111052	0	38111800	05C_0_14191	38111800	0
	05D_1_14293	31421101	0		05C_1_14218	35111052	0		05C_1_14218	38111800	0
31421130	05C_0_14191	31421130	0	35111053	004_2_12967	35111053	0	38211400	009_3_13564	38211400	0
	05C_1_14218	31421130	0	35111055	004_2_12967	35111055	0		009_4_13594	38211400	0
31421132	003_1_12834	31421132	0	35121024	05C_0_14191	35121024	0	38211500	003_1_12834	38211500	0
	03B_0_13977	31421132	0		05C_1_14218	35121024	0		03B_0_13977	38211500	0
31422064	003_1_12834	31422064	0		05D_0_14243	35121024	0	38213003	05D_0_14243	38213003	0
	03B_0_13977	31422064	0		05D_1_14293	35121024	0		05D_1_14293	38213003	0
31423043	08C_0_14518	31423043	0	35121026	05D_0_14243	35121026	0	38213503	05C_0_14191	38213503	0
31423084	001_4_12698	31423084	0		05D_1_14293	35121026	0		05C_1_14218	38213503	0
	003_1_12834	31423084	0	35121030	05D_0_14243	35121030	0	38213800	004_2_12967	38213800	0
	007_3_13177	31423084	0		05D_1_14293	35121030	0	38214001	05D_0_14243	38214001	0
	011_3_13744	31423084	0	35121031	004_2_12967	35121031	0		05D_1_14293	38214001	0
	03B_0_13977	31423084	0	35211120	004_2_12967	35211120	0	39113501	011_3_13744	39113501	0
	08C_0_14518	31423084	0	37111150	004_2_12967	37111150	0	39113502	011_3_13744	39113502	0
31423105	011_3_13744	31423105	0	37111152	004_2_12967	37111152	0	39114008	011_3_13744	39114008	0
	05D_0_14243	31423105	0	37111200	05D_0_14243	37111200	0	39114010	011_3_13744	39114010	0
	05D_1_14293	31423105	0		05D_1_14293	37111200	0	39115010	011_3_13744	39115010	0
31423130	007_3_13177	31423130	0	37111201	05D_0_14243	37111201	0	39413502	011_3_13744	39413502	0
	011_3_13744	31423130	0		05D_1_14293	37111201	0	39414008	011_3_13744	39414008	0
34110028	009_3_13564	34110028	0	37111250	004_2_12967	37111250	0	39414010	011_3_13744	39414010	0
	009_4_13594	34110028	0		05C_0_14191	37111250	0	39415010	011_3_13744	39415010	0
34110030	05D_0_14243	34110030	0		05C_1_14218	37111250	0	51356610	05C_1_14218	51356610	0
	05D_1_14293	34110030	0	37111300	05D_0_14243	37111300	0	52356559	05D_0_14243	52356559	0



SPARE PARTS INSTANCE INDEX

Code	Parts Table	Pos.	Q.ty	Code	Parts Table	Pos.	Q.ty	Code	Parts Table	Pos.	Q.ty
52356559	05D_1_14293	52356559	0	54156482	05C_1_14218	54156482	0	56156568	05C_0_14191	56156568	0
52357250	009_3_13564	52357250	0	55102678	003_1_12834	55102678	0		05C_1_14218	56156568	0
	009_4_13594	52357250	0		03B_0_13977	55102678	0	56156571	05D_0_14243	56156571	0
52456336	004_2_12967	52456336	0	55102714	007_3_13177	55102714	0		05D_1_14293	56156571	0
52456340	004_2_12967	52456340	0	55142076	009_3_13564	55142076	0	56156572	05D_0_14243	56156572	0
52456349	004_2_12967	52456349	0		009_4_13594	55142076	0		05D_1_14293	56156572	0
52456354	004_2_12967	52456354	0	55220363	007_3_13177	55220363	0	56156577	05D_0_14243	56156577	0
52456360	004_2_12967	52456360	0	55242528	009_3_13564	55242528	0		05D_1_14293	56156577	0
52456362	004_2_12967	52456362	0		009_4_13594	55242528	0	56156585	05D_0_14243	56156585	0
52456370	004_2_12967	52456370	0	55243340	007_3_13177	55243340	0		05D_1_14293	56156585	0
52456389	004_2_12967	52456389	0	55247659	08C_0_14518	55247659	0	56156591	08C_0_14518	56156591	0
52456390	004_2_12967	52456390	0	55247660	08C_0_14518	55247660	0	56156603	08C_0_14518	56156603	0
52456556	05D_0_14243	52456556	0	55247661	08C_0_14518	55247661	0	56156604	08C_0_14518	56156604	0
	05D_1_14293	52456556	0	55248038	08C_0_14518	55248038	0	56156940	007_3_13177	56156940	0
52456560	05D_0_14243	52456560	0	55248041	08C_0_14518	55248041	0	56156948	007_3_13177	56156948	0
	05D_1_14293	52456560	0	55248283	08C_0_14518	55248283	0	56157235	009_3_13564	56157235	0
52456564	05D_0_14243	52456564	0	55252316	001_4_12698	55252316	0		009_4_13594	56157235	0
	05D_1_14293	52456564	0	55256756	08C_0_14518	55256756	0	56157244	009_3_13564	56157244	0
52456567	05D_0_14243	52456567	0	55256757	08C_0_14518	55256757	0		009_4_13594	56157244	0
	05D_1_14293	52456567	0	56120364	007_3_13177	56120364	0	56157246	009_3_13564	56157246	0
53143712	011_3_13744	53143712	0	56147520	03B_0_13977	56147520	0		009_4_13594	56157246	0
53152401	003_1_12834	53152401	0	56147655	08C_0_14518	56147655	0	56157256	009_3_13564	56157256	0
53152402	003_1_12834	53152402	0	56147923	003_1_12834	56147923	0		009_4_13594	56157256	0
	03B_0_13977	53152402	0	56148037	08C_0_14518	56148037	0	56157307	009_3_13564	56157307	0
53152411	003_1_12834	53152411	0	56148285	08C_0_14518	56148285	0		009_4_13594	56157307	0
53152412	003_1_12834	53152412	0	56148287	08C_0_14518	56148287	0	56157332	08C_0_14518	56157332	0
53156327	003_1_12834	53156327	0	56149655	009_3_13564	56149655	0	56157353	009_4_13594	56157353	0
53156332	03B_0_13977	53156332	0		009_4_13594	56149655	0	56157807	05D_0_14243	56157807	0
53256553	05D_0_14243	53256553	0	56150361	08C_0_14518	56150361	0		05D_1_14293	56157807	0
	05D_1_14293	53256553	0	56152241	001_4_12698	56152241	0	56157822	05C_0_14191	56157822	0
53256601	05C_0_14191	53256601	0	56152403	003_1_12834	56152403	0	56157834	05C_1_14218	56157834	0
53257808	05D_0_14243	53257808	0	56156119	001_4_12698	56156119	0	56347854	05D_0_14243	56347854	0
	05D_1_14293	53257808	0	56156566	05D_0_14243	56156566	0		05D_1_14293	56347854	0
54156482	05C_0_14191	54156482	0		05D_1_14293	56156566	0	56356328	004_2_12967	56356328	0



SPARE PARTS INSTANCE INDEX

Code	Parts Table	Pos.	Q.ty	Code	Parts Table	Pos.	Q.ty	Code	Parts Table	Pos.	Q.ty
56356329	004_2_12967	56356329	0	58046912	013_1_13860	58046912	0	58052325	011_3_13744	58052325	0
56356330	004_2_12967	56356330	0	58046913	013_1_13860	58046913	0	58052326	011_3_13744	58052326	0
56356331	004_2_12967	56356331	0	58047649	08C_0_14518	58047649	0	58052327	011_3_13744	58052327	0
56356348	004_2_12967	56356348	0	58047662	08C_0_14518	58047662	0	58056391	004_2_12967	58056391	0
56359553	011_3_13744	56359553	0	58047875	05D_0_14243	58047875	0	58056562	05C_0_14191	58056562	0
56359554	011_3_13744	56359554	0		05D_1_14293	58047875	0		05C_1_14218	58056562	0
56456347	004_2_12967	56456347	0	58047885	05D_0_14243	58047885	0	58056563	05C_0_14191	58056563	0
56456351	004_2_12967	56456351	0		05D_1_14293	58047885	0		05C_1_14218	58056563	0
56456477	004_2_12967	56456477	0	58048000	08C_0_14518	58048000	0	58056580	08C_0_14518	58056580	0
56456478	004_2_12967	56456478	0	58048005	08C_0_14518	58048005	0	58056581	08C_0_14518	58056581	0
56456569	05C_0_14191	56456569	0	58048009	08C_0_14518	58048009	0	58056582	05C_0_14191	58056582	0
	05C_1_14218	56456569	0	58049670	08C_0_14518	58049670	0		05C_1_14218	58056582	0
58002429	08C_0_14518	58002429	0	58051670	08C_0_14518	58051670	0	58056593	08C_0_14518	58056593	0
58002538	08C_0_14518	58002538	0	58052018	012_2_13824	58052018	0	58056595	08C_0_14518	58056595	0
58025866	05C_0_14191	58025866	0	58052019	012_2_13824	58052019	0	58056596	08C_0_14518	58056596	0
	05C_1_14218	58025866	0	58052020	012_2_13824	58052020	0	58056605	08C_0_14518	58056605	0
58025867	05C_0_14191	58025867	0	58052021	012_2_13824	58052021	0	58056606	08C_0_14518	58056606	0
	05C_1_14218	58025867	0	58052022	012_2_13824	58052022	0	58056942	007_3_13177	58056942	0
58025868	05C_0_14191	58025868	0	58052023	012_2_13824	58052023	0	58056991	001_4_12698	58056991	0
	05C_1_14218	58025868	0	58052024	012_2_13824	58052024	0	58057247	009_3_13564	58057247	0
58025869	05C_0_14191	58025869	0	58052029	012_2_13824	58052029	0		009_4_13594	58057247	0
	05C_1_14218	58025869	0	58052033	012_2_13824	58052033	0	58057263	08C_0_14518	58057263	0
58026222	08C_0_14518	58026222	0	58052034	012_2_13824	58052034	0	58057295	08C_0_14518	58057295	0
58042067	08C_0_14518	58042067	0	58052144	012_2_13824	58052144	0	58057296	08C_0_14518	58057296	0
58042202	08C_0_14518	58042202	0	58052145	012_2_13824	58052145	0	58057306	08C_0_14518	58057306	0
58043053	003_1_12834	58043053	0	58052146	012_2_13824	58052146	0	58057385	001_4_12698	58057385	0
	03B_0_13977	58043053	0	58052147	012_2_13824	58052147	0	58057676	013_1_13860	58057676	0
	05D_0_14243	58043053	0	58052148	012_2_13824	58052148	0	58057678	013_1_13860	58057678	0
	05D_1_14293	58043053	0	58052149	012_2_13824	58052149	0	58057698	009_3_13564	58057698	0
58043086	004_2_12967	58043086	0	58052150	012_2_13824	58052150	0		013_1_13860	58057698	0
58043117	003_1_12834	58043117	0	58052151	012_2_13824	58052151	0	58057712	013_1_13860	58057712	0
58043176	009_3_13564	58043176	0	58052154	012_2_13824	58052154	0	58057714	009_3_13564	58057714	0
	009_4_13594	58043176	0	58052155	012_2_13824	58052155	0	58057722	013_1_13860	58057722	0
58043344	08C_0_14518	58043344	0	58052274	011_3_13744	58052274	0	58057724	013_1_13860	58057724	0



SPARE PARTS INSTANCE INDEX

Code	Parts Table	Pos.	Q.ty	Code	Parts Table	Pos.	Q.ty
58057732	013_1_13860	58057732	0	59056982	001_4_12698	59056982	0
58057767	013_1_13860	58057767	0	59056986	001_4_12698	59056986	0
58057768	013_1_13860	58057768	0	59056989	009_3_13564	59056989	0
58057770	013_1_13860	58057770	0		009_4_13594	59056989	0
58057771	013_1_13860	58057771	0	59057100	08C_0_14518	59057100	0
58057772	013_1_13860	58057772	0	59057101	08C_0_14518	59057101	0
58150313	08C_0_14518	58150313	0	59057240	009_3_13564	59057240	0
59015425	003_1_12834	59015425	0		009_4_13594	59057240	0
	03B_0_13977	59015425	0	59057252	009_3_13564	59057252	0
59047450	001_4_12698	59047450	0		009_4_13594	59057252	0
59047743	011_3_13744	59047743	0	59057270	009_3_13564	59057270	0
59047745	011_3_13744	59047745	0		009_4_13594	59057270	0
59047927	001_4_12698	59047927	0	59057308	009_3_13564	59057308	0
59056051	001_4_12698	59056051	0		009_4_13594	59057308	0
59056089	001_4_12698	59056089	0	59057309	009_3_13564	59057309	0
59056111	001_4_12698	59056111	0		009_4_13594	59057309	0
59056365	004_2_12967	59056365	0	59057824	05C_0_14191	59057824	0
59056383	004_2_12967	59056383	0	59057831	03B_0_13977	59057831	0
59056555	05D_0_14243	59056555	0	59059551	011_3_13744	59059551	0
	05D_1_14293	59056555	0	59059561	011_3_13744	59059561	0
59056558	05C_0_14191	59056558	0	59059571	011_3_13744	59059571	0
	05C_1_14218	59056558	0	59259555	011_3_13744	59259555	0
59056573	05D_0_14243	59056573	0	59259563	011_3_13744	59259563	0
	05D_1_14293	59056573	0	59259567	011_3_13744	59259567	0
59056574	05D_0_14243	59056574	0	59259578	011_3_13744	59259578	0
	05D_1_14293	59056574	0	59259580	011_3_13744	59259580	0
59056583	05D_0_14243	59056583	0	92243685	011_3_13744	92243685	0
	05D_1_14293	59056583	0	92457794	011_3_13744	92457794	0
59056584	05D_0_14243	59056584	0				
	05D_1_14293	59056584	0				
59056935	007_3_13177	59056935	0				
59056975	009_3_13564	59056975	0				
	009_4_13594	59056975	0				
59056980	007_3_13177	59056980	0				